

# 12A 3.96mm pitch Wire-to-Board Connectors

DF63SF Series



## ■ Features

### 1. Rated for up to 12A

DF63SF has the capacity to handle a max of 12A when using 16 AWG wire. (Please refer to the chart for the rated current in each pin counts.)

### 2. The small vertical-mating design allows for easy assembly

Vertical mating and horizontal wiring (Side Feed) enables a high flexibility in the arrangement of components. (Fig.1)

### 3. Secure Mating with a Clear Tactile Click

A large area to press down the socket at the center. Secure mating with a clear tactile click with sharp sound. (Fig.2)

### 4. Molded lance design

The lance is actually part of the housing instead of being a part of the terminal. This prevents tangled wires during assembly.

### 5. THR mounting

Contribute to the improvement of productivity by corresponding to the automatic mounting machine.

### 6. Glow Wire compliance (Compliant with IEC 60695-2-11)

#### \* Supports 7.92mm pitch

Also supports 7.92mm pitch with 2 pos. by skipped pin.

(UL, C-UL, Listed)

### Small & Vertical Mating

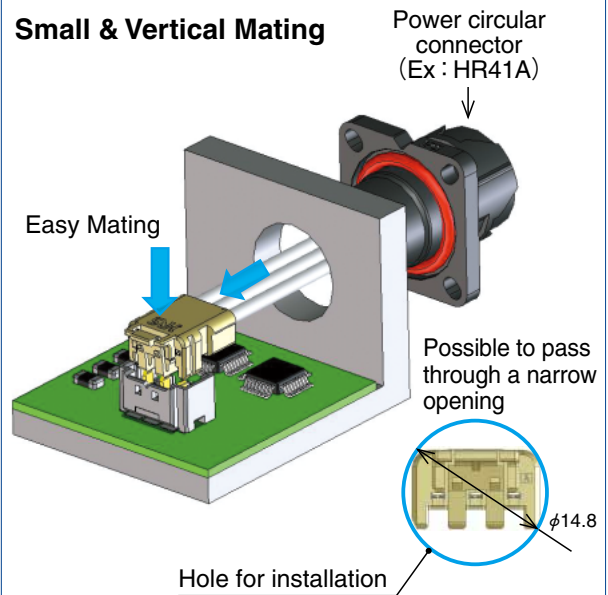

### Minimized keep-out space

Other components can be mounted under the cables

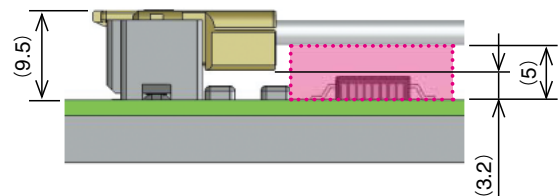

### Comparison with general right-angle type

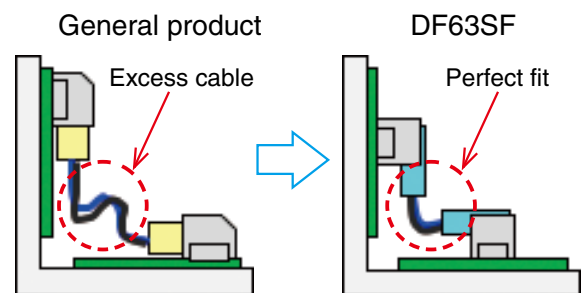
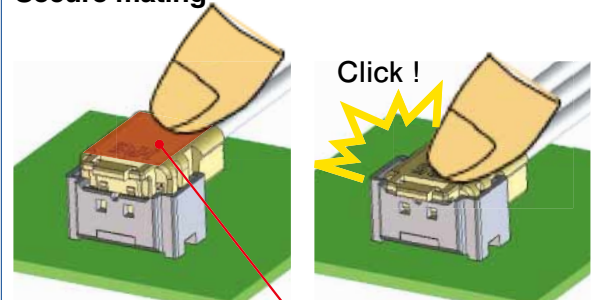

Fig.1

### Secure mating



Easy-to-push with one finger

Fig.2

## Product Specifications

Ratings	Current Rating (Note 1)	No. of Contacts	16 AWG	18 AWG	Operating temperature range -55 to 105°C (Note 2) Operating humidity range 20 to 80% (Note 3) Storage temperature range -10 to 60°C (Note 4) Storage humidity range 40 to 70% (Note 4)
		3	12A	10A	
	2 (7.92mm pitch)	15A	13A	UL/TÜV File No. and Recognition No. UL : E52653 C-UL : E52653 TÜV : R50372836	
	Voltage Rating	Specification	AC/DC 630V		
		UL,C-UL	AC/DC 600V		
		TÜV	AC/DC 300V		

Item	Specifications	Conditions
1. Insulation Resistance	No less than 1,000MΩ	Measured at DC 500V
2. Withstand Voltage	No flashover or breakdown	AC 2,200V is applied for one minute.
3. Contact Resistance	No more than 10mΩ	Measured at 1mA (DC or 1000Hz) and no higher than 20mV
4. Vibration Resistance	No electrical discontinuity of 1μs or greater	Frequency 10-55Hz, half amplitude 0.75 mm, 10 times in each of the three directions
5. Shock Resistance	No electrical discontinuity of 1μs or greater	Accelerated velocity : 490 m/s <sup>2</sup> for 11ms, half-sine wave in 3 directions, 3 times for each direction
6. Moisture-resistance	Contact resistance : no more than 20mΩ Insulation resistance : no less than 500MΩ	Temperature : 40±2°C ; humidity : 90 to 95%, left as it is for 96 hours
7. Temperature cycles	Contact resistance : no more than 20mΩ Insulation resistance : no less than 1,000MΩ	-55°C : 30 minutes → 85°C : 30 minutes 5 cycles
8. Durability	Contact resistance : no more than 20mΩ	50 mating cycles
9. Solder heat resistance	The resin parts should withstand the temperature and resist melting.	Reflow : according to the Recommended Temperature Profile Hand soldering : temperature of soldering iron at 350°C±10°C for 5 seconds

Note 1 : This is the maximum current rating while all pins are powered or used as all power lines.

Note 2 : Includes temperature rise caused by current flow.

Note 3 : Use without condensation on parts.

Note 4 : The storage condition refers to long-term storage of the product on the shelf before assembly. Please use the operating temperature for temporary storage such as pre-assembly and during shipping.

## Materials / Finish

Component	Part	Material	Finish	UL Specification
Header	Insulator	LCP	Black	UL94V-0
	Contact	Copper alloy	Gold plated	—
Crimp socket	Insulator	PBT (glass-reinforced)	Black	UL94V-0
Crimp contact	Contact	Copper alloy	Gold plated	—

## Product Number Structure

Refer to the chart below when determining the product specifications from the product number.

Please select from the product numbers listed in this catalog when placing orders.

### ●Header

**DF 63SF - \* P - 3.96 TV**

① ② ③ ④ ⑤ ⑥

① Series name : DF	⑤ Contact Pitch : 3.96mm 7.92mm
② Series No. : 63SF	⑥ Termination style TV : THR vertical type
③ Number of contacts : 2, 3	
④ Connector type P : Header	

### ●Crimp socket

**DF 63SF - \* S - 3.96 C**

① ② ③ ④ ⑤ ⑥

① Series name : DF	⑤ Contact Pitch : 3.96mm
② Series No. : 63SF	⑥ Termination style C : Crimp housing
③ Number of contacts : 3	
④ Connector type S : Crimp socket	

### ●Crimp contact

**DF 63SF - 1618 SCFA**

① ②

① Applicable Conductor 1618 16 to 18 AWG
② Packaging SCFA : Socket contacts•Reel•Gold plated

## ■ Straight Header (THR)

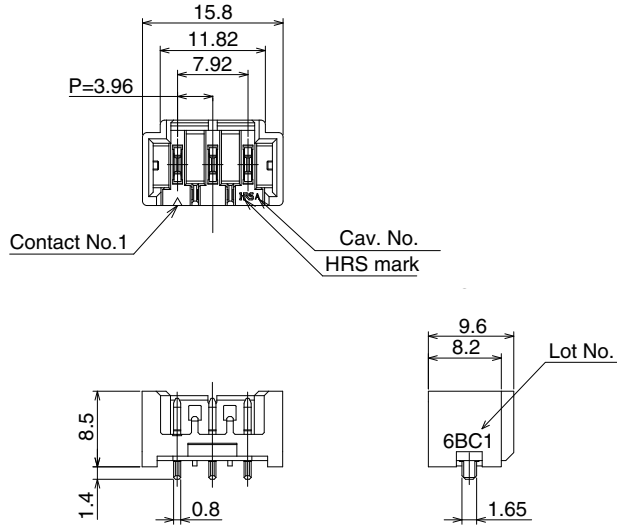

### Recommended PCB Layout (t=1.6mm)

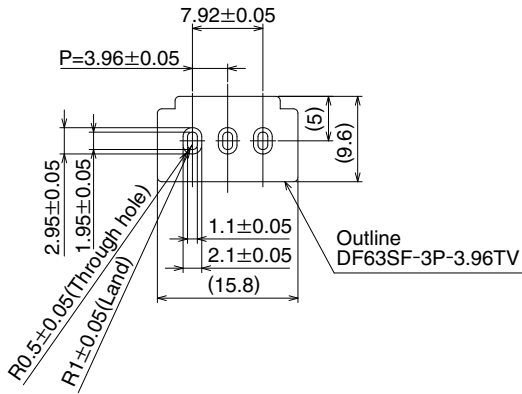

[Specification number]\*\*

(51): Gold plated (0.2μm), embossed packaging  
 (52): Gold plated (0.76μm), embossed packaging

Part No.	HRS No.	No. of Contacts
DF63SF-3P-3.96TV (**)	680-0701-0 **	3
DF63SF-2P-7.92TV (**)	680-0704-0 **	2

Note : Please place orders for embossed packaged products in multiples 450 (450 pcs/reel).

## ◆ Packaging Specification

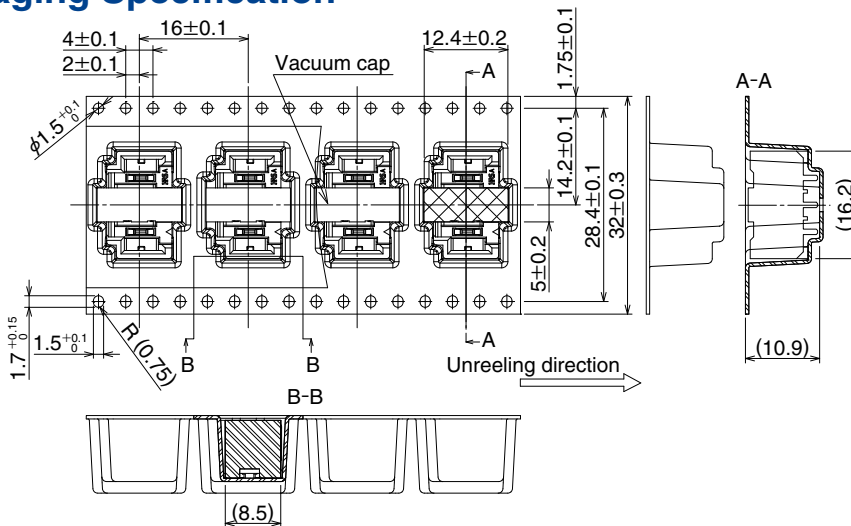

### ● Style of reel

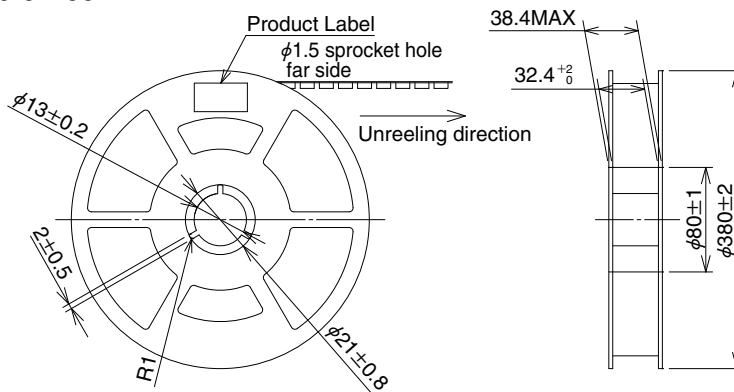

### ■ Crimp Socket

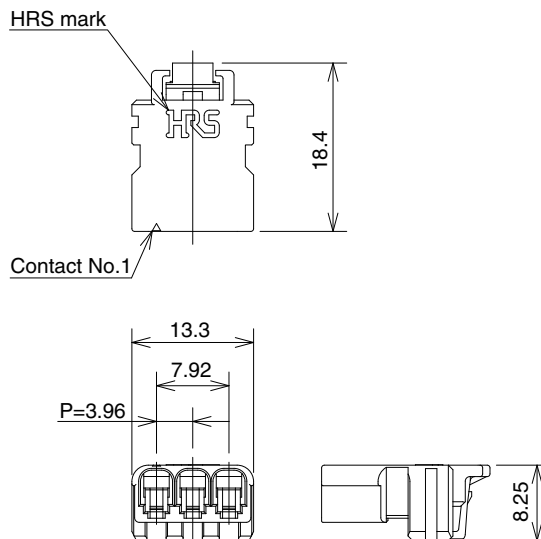

Part No.	HRS No.	No. of Contacts
DF63SF-3S-3.96C	680-0702-0	3

Note : Please specify the number of packs (100 pcs/pack) when placing orders.

### ■ Crimp Contact

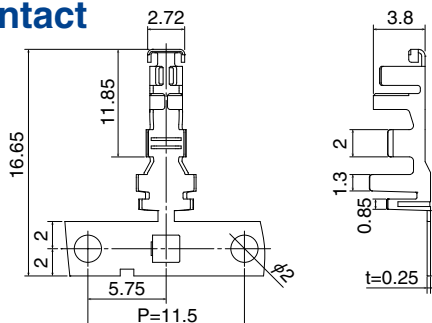

Part No.	HRS No.	Type	Quantity	Finish
DF63SF-1618SCFA	680-0703-0	Reel contact (Note 1)	3,000 pcs/reel	Gold plated
DF63SF-1618SCA	Under planning	Pack contact (Note 2)	100 pcs/pack	0.2μm
DF63SF-1618SCFA (05)	680-0703-0 05	Reel contact (Note 1)	3,000 pcs/reel	Gold plated
DF63SF-1618SCA (05)	Under planning	Pack contact (Note 2)	100 pcs/pack	0.76μm

Note 1 : The package style is 3,000 pcs/reels. Please place orders in multiples of reels.

Note 2 : The package style is 100 pcs/packs. Please place orders in multiples of packs.

### ● Applicable wire (Tinned Annealed Copper Wire)

Conductor size (Core structure)	Jacket outer diameter	Recommended wire (Note 1)	Strip length (Note 2)
16 AWG 26pieces/0.254mm in diameter	φ2.40mm	UL1007	3.1 to 3.8mm
16 AWG 54pieces/0.18mm in diameter	φ2.53mm	UL1430	
18 AWG 34pieces/0.18mm in diameter	φ2.10mm	UL1007	

Note 1 : Please contact our Sales representative when using wires other than applicable wires.

Note 2 : The strip length is a reference value. Please adjust the strip length accordingly for specifications and requirements.

Refer to the crimping quality standard (ATAD-H0891-00) for details.

### ◆ Applicable Crimping Tool

Type	Part No.	HRS No.	Applicable contact
Applicator	AP105-DF63SF-1618S	901-4651-0 00	DF63SF-1618SCFA (**)
	CHX022400H-UP (Note 3)	—	
Press body	CM-105C	901-0001-0 00	—
Hand tool	HT802/DF63SF-1618SCFA (Note 2)	550-0440-0 00	DF63SF-1618SCA (**)
Contact extraction tool	DF-C-PO(B)	550-0179-2 00	—

Note 1 : Any problems that occur from using tools other than those specified by Hirose, are not covered by warranty.

Note 2 : Hand tool dies cannot be switched. The compatible wire is Limited to UL1007 (16 to 18 AWG).

Note 3 : Applicator manufactured by JAPAN AUTOMATIC MACHINE (J.A.M.). Please access to web of J.A.M., if you make inquiries about the applicator or crimp defect. (URL : <http://www.jam-net.co.jp>)

## ◆ Precautions

<p>1. Recommended Temperature Profile (Compatible with lead-free soldering)</p>	<p>[Applicable Conditions]</p> <ol style="list-style-type: none"> <li>1. Peak temperature : 250°C max.</li> <li>2. Soldering area : 220°C min. for less than 60 seconds</li> <li>3. Preheating area : 150°C to 180°C for 90 to 120 seconds</li> <li>4. Number of times : no more than 2 times</li> </ol> <p>* Measurement is conducted at the contact lead part Soldering results may change depending on conditions such as solder paste type, manufacturer, PCB size, and other soldering materials. Please determine all mounting conditions before use. Note 1 : This temperature profile is a recommended value. Note 2 : Prohibited backside-surface mounting.</p>
<p>2. Recommended manual soldering conditions</p>	<p>Temperature of soldering iron : 350±10°C, soldering time : within 5 seconds</p>
<p>3. Recommended screen thickness and board thickness</p>	<p>Screen thickness : 0.15mm Board thickness : 1.6mm</p>
<p>4. Warpage of the Board</p>	<p>A maximum of 0.02mm at the center of connector, as measured from either end of the connector</p>
<p>5. Cleaning Conditions</p>	<p>IPA cleaning is allowed. (Cleaning is not recommended due to potential changes in mating action and other variables. Please contact us if you use other cleaning agents.)</p>
<p>6. Noteworthy Points</p>	<ol style="list-style-type: none"> <li>1. Please note that any mating operation of the connector when not mounted on the board may cause damage or deformation of the contacts.</li> <li>2. During hand soldering, do not apply flux, as it will flow over the connector.</li> <li>3. This housing color may have slight variations depending on the production lot. This color variation does not affect performance.</li> <li>4. The connector could be damaged if it is pulled out forcibly. When it is hard to pull out, push it in slightly first and then depress the lock and un-mate.</li> <li>5. When thick, short sections of wire are used, the connector could be deformed due to the force of the wires' position. Route cables in such a way that they do not twist when being installed.</li> <li>6. Make sure to turn off the power when mating or un-mating the connector.</li> <li>7. Please do not touch any area around the contact part with your hand when the power is on; it could be very dangerous.</li> <li>8. Please refer to "DF63SF Series mating and unmating Procedure Document (ETAD-H0901-00)" for points in handling regarding mating operations.</li> <li>9. Please refer to "Harness procedure manual (ETAD-H0897-00)" for points in harness operations.</li> </ol>

## ◆ Removing Contacts

- Contact extraction tool : DF-C-PO (B)
- For Crimp contacts : DF63SF-1618SC (F) A (\*\*)
- Procedure

When pulling out an inserted crimp terminal, please lift mold lance with using, DF-C-PO (B) or pined needle and then pulling the cable. Due to any previous repairs, the strength of the lance could have been compromised. Hirose recommends the use of a new crimp housing to assure proper performance.

Sectioned drawing of the housing

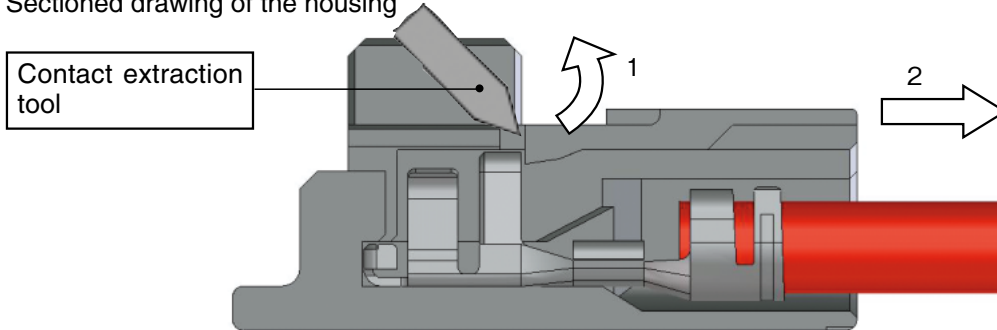

### Caution

Please be very careful when removing the contact work so that you don't become injured by the protruding part of the crimp contact.

## ◆ Mated dimensions

- Wire-to-Board Connection using the straight pin header

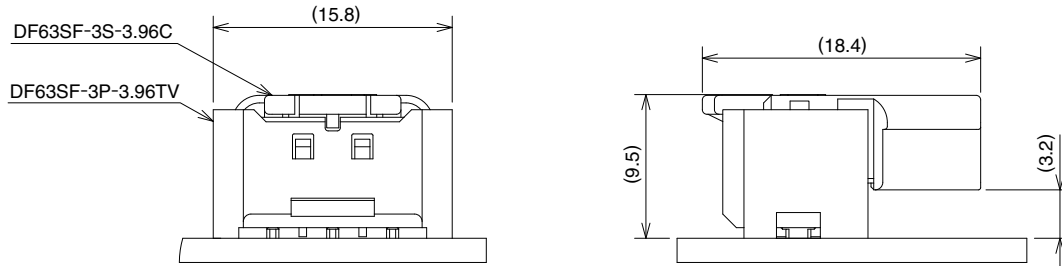

## ◆ Rated values

Please avoid using the device above the rated values. Also, do not insert or pull out energized or "live" wires.

## ◆ Operating environment

Please contact us if you are designing this connector into environmental conditions where high and low temperatures are repeated.

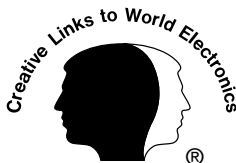

**HIROSE ELECTRIC CO.,LTD.**

2-6-3,Nakagawa Chuoh,Tsuzuki-Ku,Yokohama-Shi 224-8540,JAPAN

TEL: +81-45-620-3526 Fax: +81-45-591-3726

<http://www.hirose.com>

<http://www.hirose-connectors.com>