

0.4mm Pitch/1.5mm Height, Positive Lock, Shielded Board to Board/Board to FPC Connector

DF40GL Series

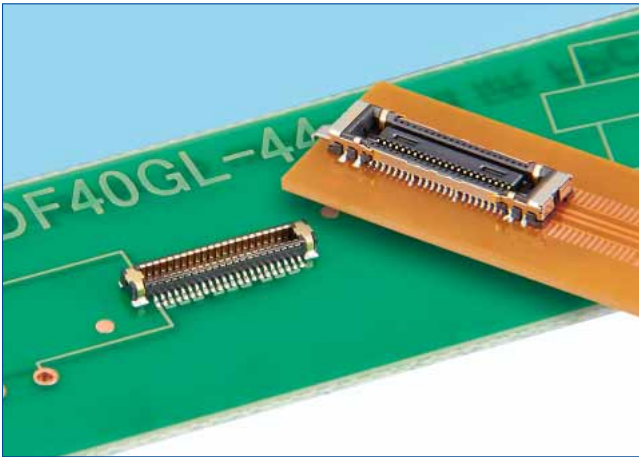

■ Features

1. Positive lock

Positive lock with blade lock design.
Prevents offset mating due to impact.

2. Supports high speed transmission

Meets USB Type C and PCIe Gen3 standards.

3. Shield and grounding design

Excellent EMI shielding.

4. Long effective mating length

The world's longest effective mating length of 0.45mm, producing high contact reliability.

5. Smooth mating operation

Guidance ribs ensure 0.4mm self-alignment range
In addition, secure mating with clear tactile click.

■ Usage

Suitable for devices which require high mating reliability and shock-resistance, such as on-board, medical and portable devices etc.

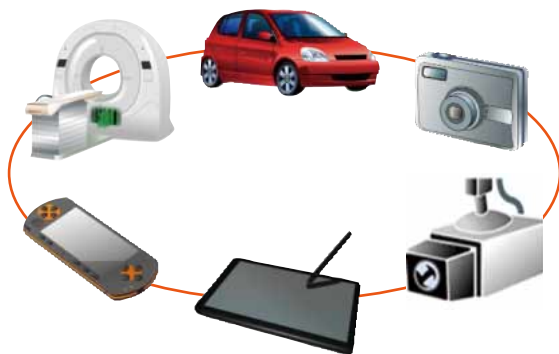

■ Environmental

•Halogen-free*

*As defined by IEC 61249-2-21

Br : 900ppm max, Cl : 900ppm max

Br+Cl : 1500ppm max

<Advantages of positive lock design>

Conventional connectors needed shock absorbent material to prevent offset mating due to impact. DF40GL Series eliminates the need for the shock absorbent material with a positive lock design.

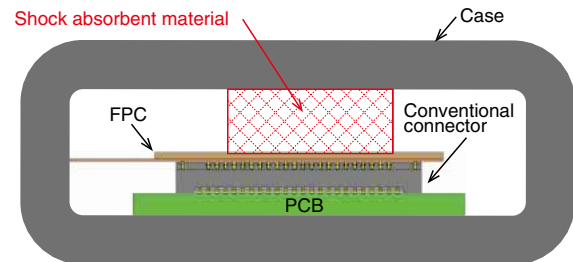

No disconnect by drop impact

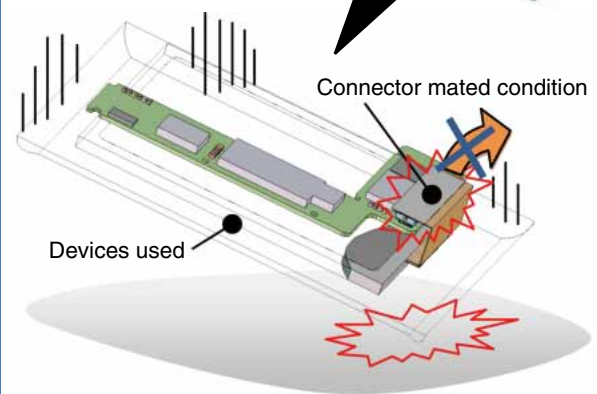

<Advantages of shielding and grounding design>

DF40GL Series has shield and lead ground producing excellent EMI performance.

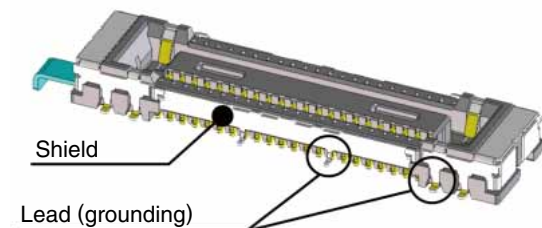

Excellent EMI performance with shielding and grounding structure

Near magnetic field simulation (4.5GHz MAX)

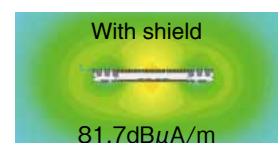
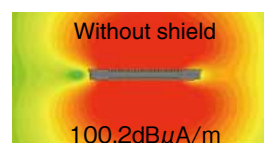

Product Specifications

Ratings	Rated Current 0.35A (Note 1)	Operating Temperature Range -55 to +85°C (Note 1)	Storage Temperature Range -10 to +60°C (Note 2)
	Rated Voltage AC, DC 30V	Operating Humidity Range 20 to 80%	Storage Humidity Range 40 to 70% (Note 2)

Items	Specifications	Conditions
1. Insulation Resistance	50MΩ min	Measured with DC 100V
2. Withstanding Voltage	No flashover or breakdown	Apply AC 100V for 1 minute
3. Contact Resistance	90mΩ max	Measured with AC 20mV, 1 kHz and 1mA
4. Vibration Resistance	No electrical discontinuity of 1μs or greater	Frequency 10-55 Hz, half amplitude 0.75mm, 3 directions for 2 hours
5. Humidity Resistance	Contact resistance : 90mΩ max Insulation resistance : 25mΩ min	Left at temperature 40 ± 2°C, humidity 90 to 95%, 96 hours
6. Temperature Cycles	Contact resistance : 90mΩ max Insulation resistance : 50mΩ min	(-55°C : 30 minutes → 5~35°C : 10 minutes → 85°C : 30 minutes → 5~35°C : 10 minutes) 5 cycles
7. Durability	Contact resistance : 90mΩ max	30 mating cycles
8. Lock strength	30N min	Apply pull force in vertical direction.
9. Soldering Heat Resistance	Should be no melting of resin parts that affects its performance	Reflow : according to the Recommended Temperature Profile Hand solder : Soldering iron temperature 350°C, no more than 3 seconds.

Note 1 : Includes temperature rise caused by current flow.

Note 2 : The term "storage" here refers to products stored for a long period prior to board mounting and use. The operating temperature and humidity range covers the non-energized condition of connectors after board mounting and the temporary storage conditions during transportation, etc.

Materials / Finish

Product	Component	Materials	Finish	UL Regulation
Receptacle/Header	Insulator	LCP	Black	UL94V-0
	Contact	Phosphor bronze	Gold plating	————
Receptacle	Shielding	Phosphor bronze	Gold plating	————
Receptacle	Lock lever	Stainless steel	————	————
Header	Metal fittings lock	Stainless steel	Gold plating	————

Product Number Structure

Refer to the chart below when determining the product specifications from the product number.
Please select from the product numbers listed in this catalog when placing orders.

●Receptacle/Header

DF 40 GL – * DS – 0.4 V (51)

① ② ③ ④ ⑤ ⑥ ⑦ ⑧

① Series Name : DF	⑦ Contact Pitch : 0.4mm
② Series No. : 40	⑧ Mating direction V : Vertical SMT
③ Style G : With shield L : Positive lock	⑧ Gold plating specification and packaging (51) : Gold plating thickness 0.05μm Emboss tape packaging (Receptacle : 4,000pcs/reel) (Header : 5,000pcs/reel) (58) : Gold plating thickness 0.05μm Emboss tape packaging (Receptacle, Header : 1,000pcs/reel)
④ No. of Contacts	
⑤ Connector Type DS : Double row receptacle DP : Double row header	

Receptacle

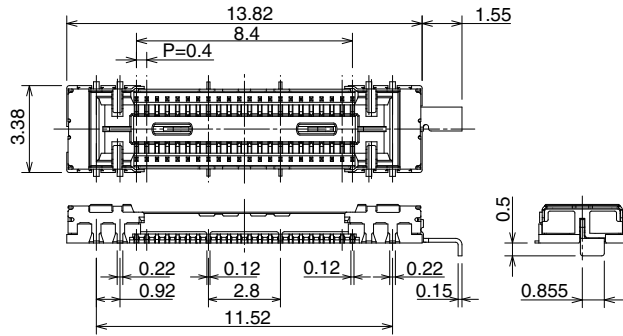
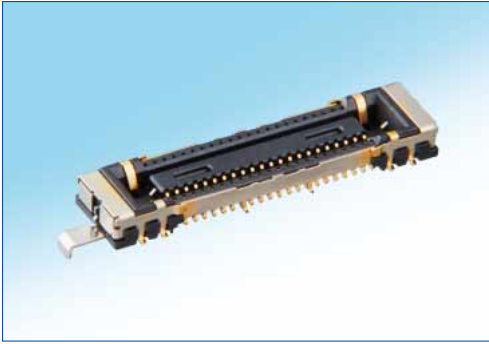

Recommended PCB mounting pattern

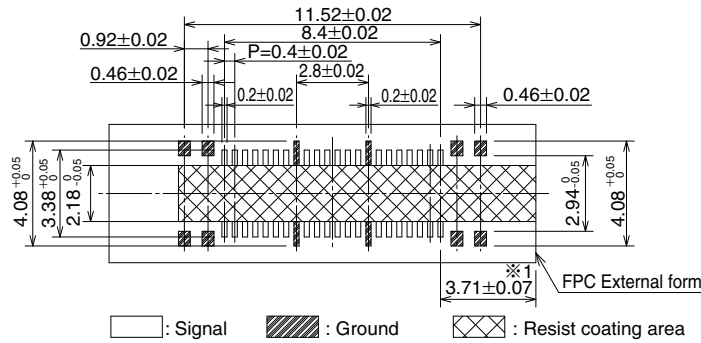

Recommended metal mask dimensions (metal mask thickness 120µm)

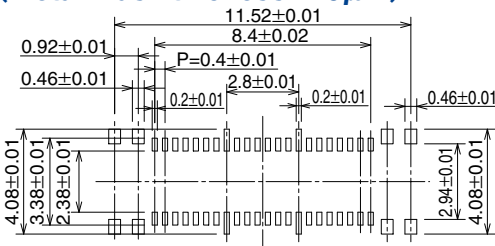

※1 : Caution! To insure proper lock lever operation, the FPC needs to be within the dimensions specified.

Part No.	HRS No.	No. of Contacts
DF40GL-44DS-0.4V(51)	684-4411-0 51	44

Note 1 : Please place orders by full reel.

Header

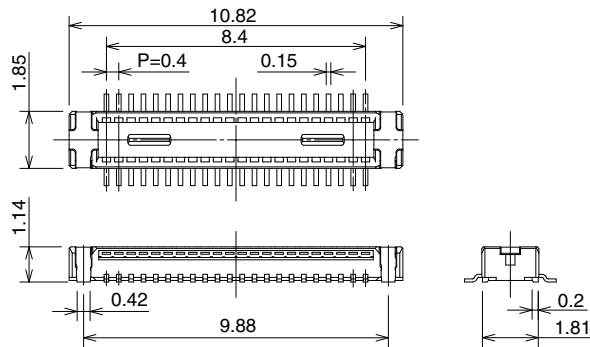

Recommended PCB mounting pattern

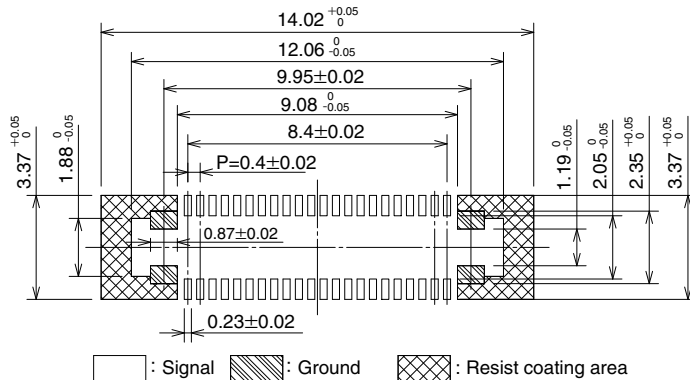

Recommended metal mask dimensions (metal mask thickness 120µm)

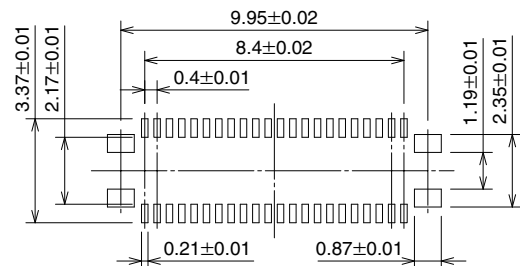

Part No.	HRS No.	No. of Contacts
DF40GL-44DP-0.4V(51)	684-4412-0 51	44

Note 1 : Please place orders by full reel.

Note 2 : This connector is Not polarized.

◆ Embossed Carrier Tape Dimensions (JIS C 0806 compliant)

● Receptacle

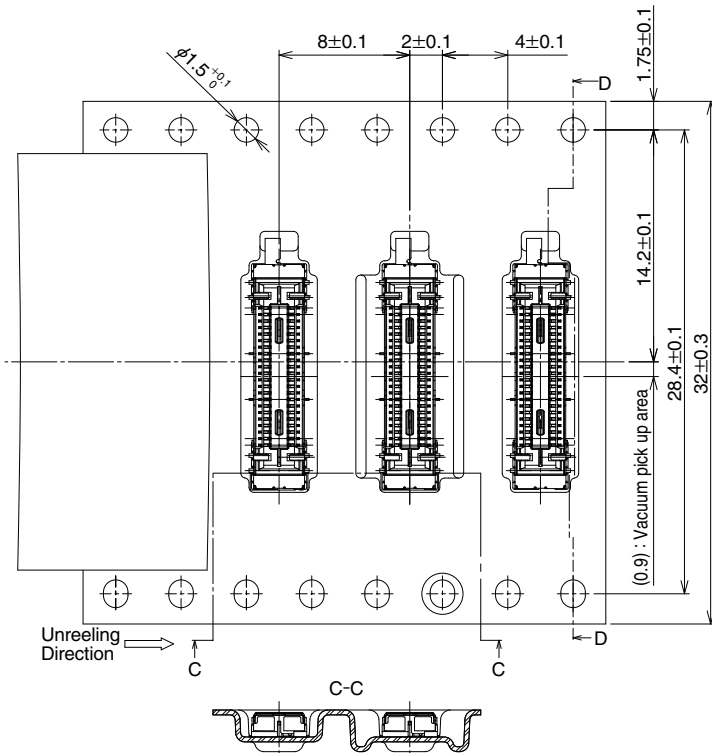

● Reel Condition Dimensions

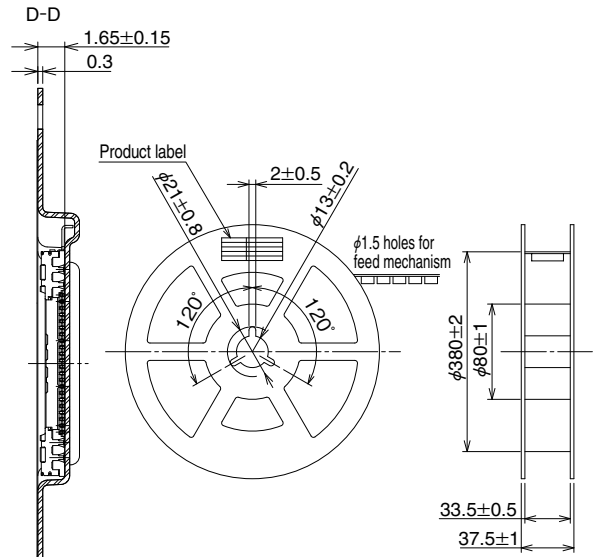

Part No.	No. of Contacts
DF40GL-44DS-0.4V(51)	44

● Header

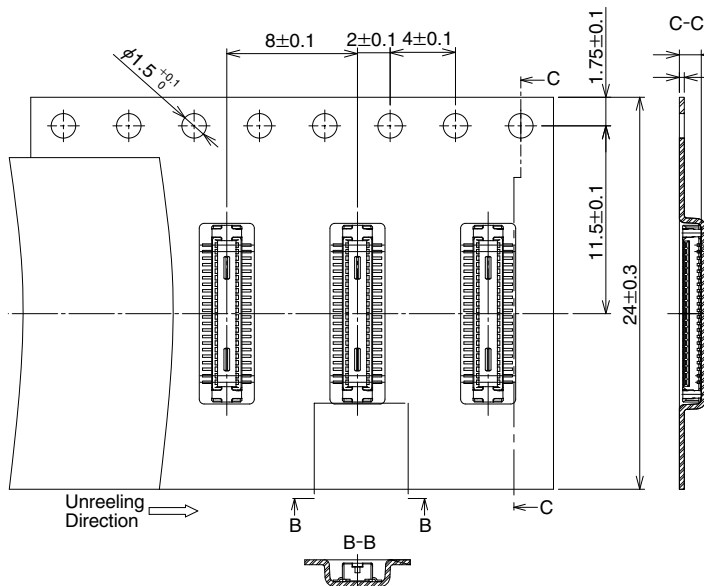

● Reel Condition Dimensions

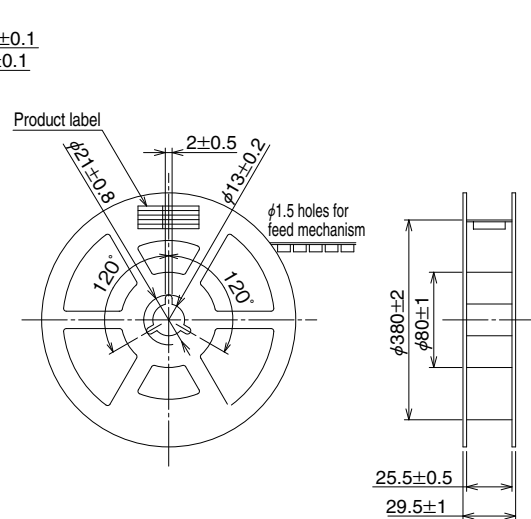

Part No.	No. of Contacts
DF40GL-44DS-0.4V(51)	44

◆ Operating Precautions

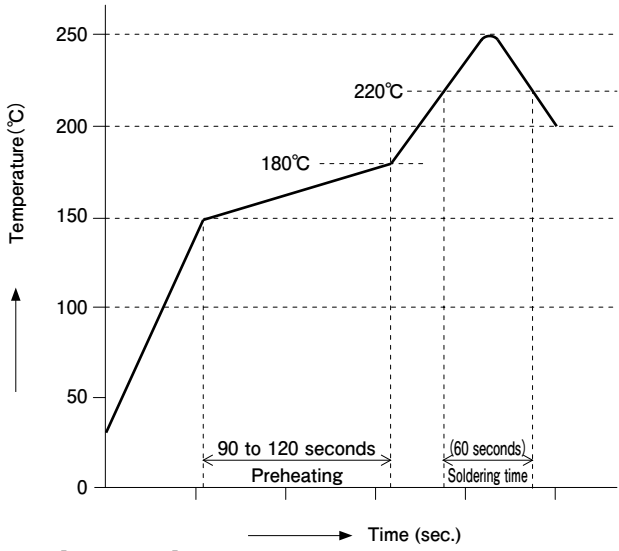
1. Recommended Solder Profile	 <p>【Conditions】</p> <ol style="list-style-type: none"> 1. Peak temperature Max of 250°C 2. Heating part Min of 220°C within 60 seconds 3. Preheating part 150 to 180°C 90 to 120 seconds 4. Number of times Maximum of 2 cycles <p>Note 1 : The temperature shows PCB surface temperature near the connector lead part.</p>
2. Recommended hand solder conditions	Soldering iron temperature 340 ±10°C, solder time no more than 3 seconds
3. Recommended screen thickness : Opening ratio (pattern area ratio)	Thickness : 0.12mm Opening ratio : 80% for contact, and 100% for shielding on the DS side. 80% for contact, and 100% for metal fittings on the DP side.
4. Leaning of PCB	Max 0.02mm at the center of connector (using both edges of connector as criteria)
5. Washing	Cleaning/washing is not recommended for this connector. Cleaning agents can deteriorate the mechanical operation and the environmental resistance of this connector.
6. Precautions	<ul style="list-style-type: none"> ■ Do not mate or unmate these connectors until they are mounted, failure to follow this precaution can lead to deformation or damage to these connectors. ■ Provide another form of support to the PCB, this connector was not designed to be the main form of support. ■ Mating and unmating with excessive force can cause damage. ■ Do not apply excessive amounts of flux as it may cause excess solder and flux wicking. ■ There may be a slight variance in the color of the molding between production lots, this variance will not affect the performance of the connector. ■ Refer to the next page for the handling precautions when mating and unmating the connectors.

● Handle with care when mating a connector

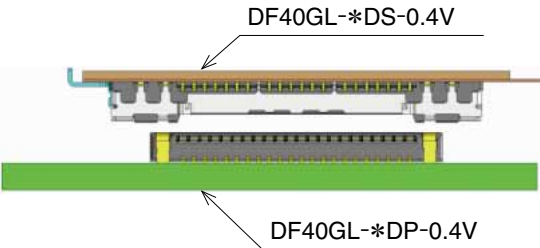
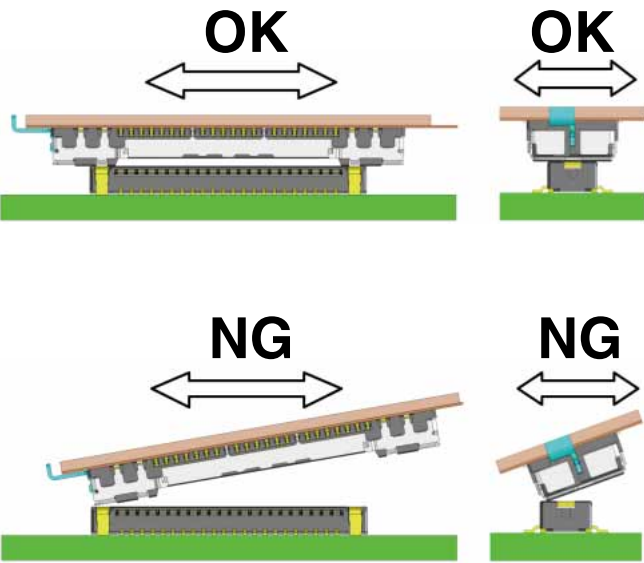
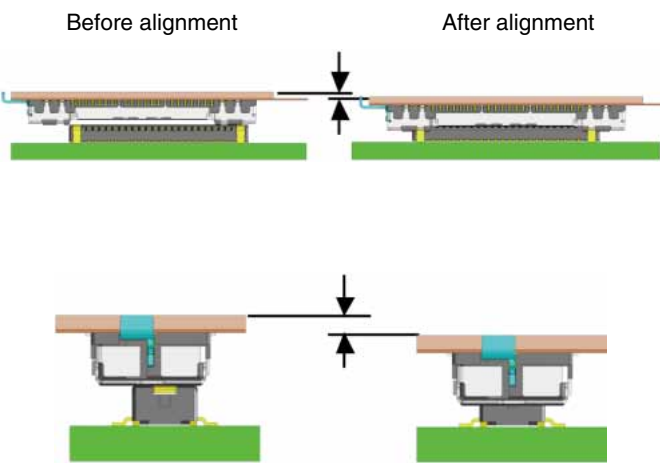
 <p>DF40GL-*DS-0.4V</p> <p>DF40GL-*DP-0.4V</p>	
 <p>OK</p> <p>OK</p> <p>NG</p> <p>NG</p>	<p>When aligning, look for the guide port by moving the connector in X and Y directions parallel to the mating connector.</p> <p>If Z axis pressure is applied while not parallel to the mate, the connector may crack or edges shaved.</p>
 <p>Before alignment</p> <p>After alignment</p>	<p>When the connector is correctly aligned, it is guided and lowers into place, which can be felt by the operator.</p> <p>After connectors are aligned and can't be moved in the X and Y axis. Complete mating operation.</p>

Feb.1.2019 Copyright 2019 HIROSE ELECTRIC CO., LTD. All Rights Reserved.

● Handle with care when un-mating connectors

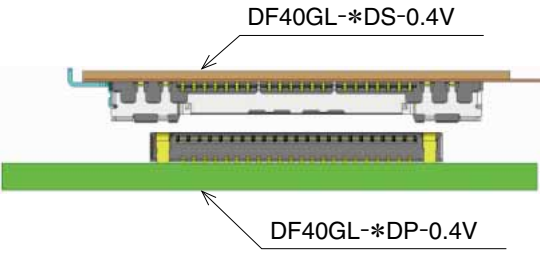
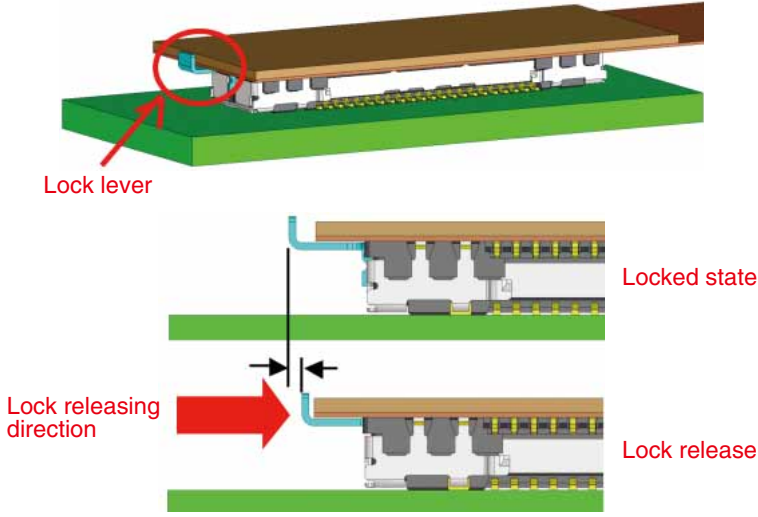
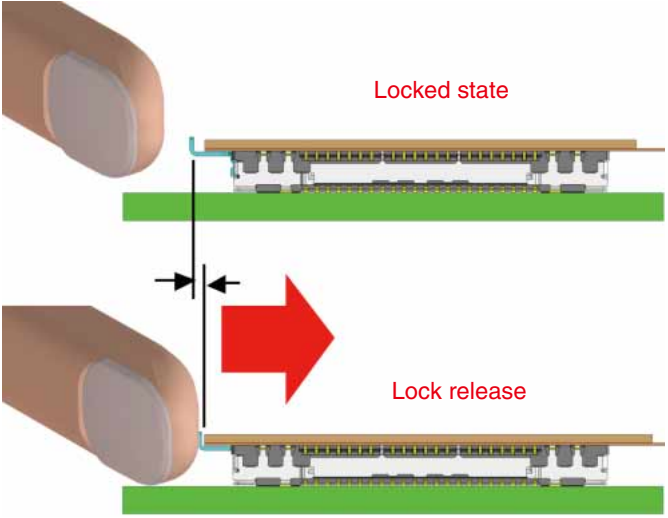
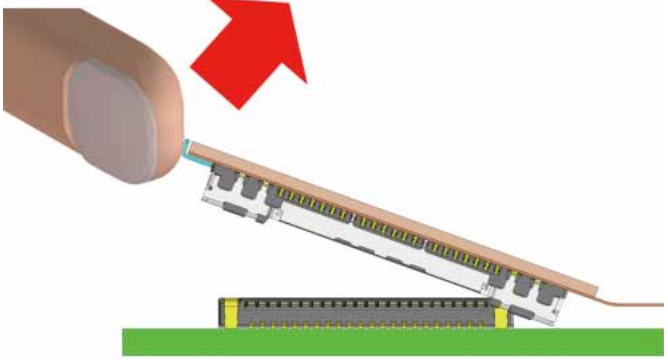
 <p>DF40GL-*DS-0.4V</p> <p>DF40GL-*DP-0.4V</p>	
 <p>Lock lever</p> <p>Locked state</p> <p>Lock releasing direction</p> <p>Lock release</p>	<p>To unmate, press and hold the lock release lever while the connector is unmated.</p>
<p>STEP1</p>  <p>Locked state</p> <p>Lock release</p>	<p>Push the lock lever to release the lock. By pushing the rim of the FPC, the lock lever is pressed at the same time, and the lock is released.</p>
<p>STEP2</p> 	<p>Raise the FPC upward direction while pressing the lock lever.</p>

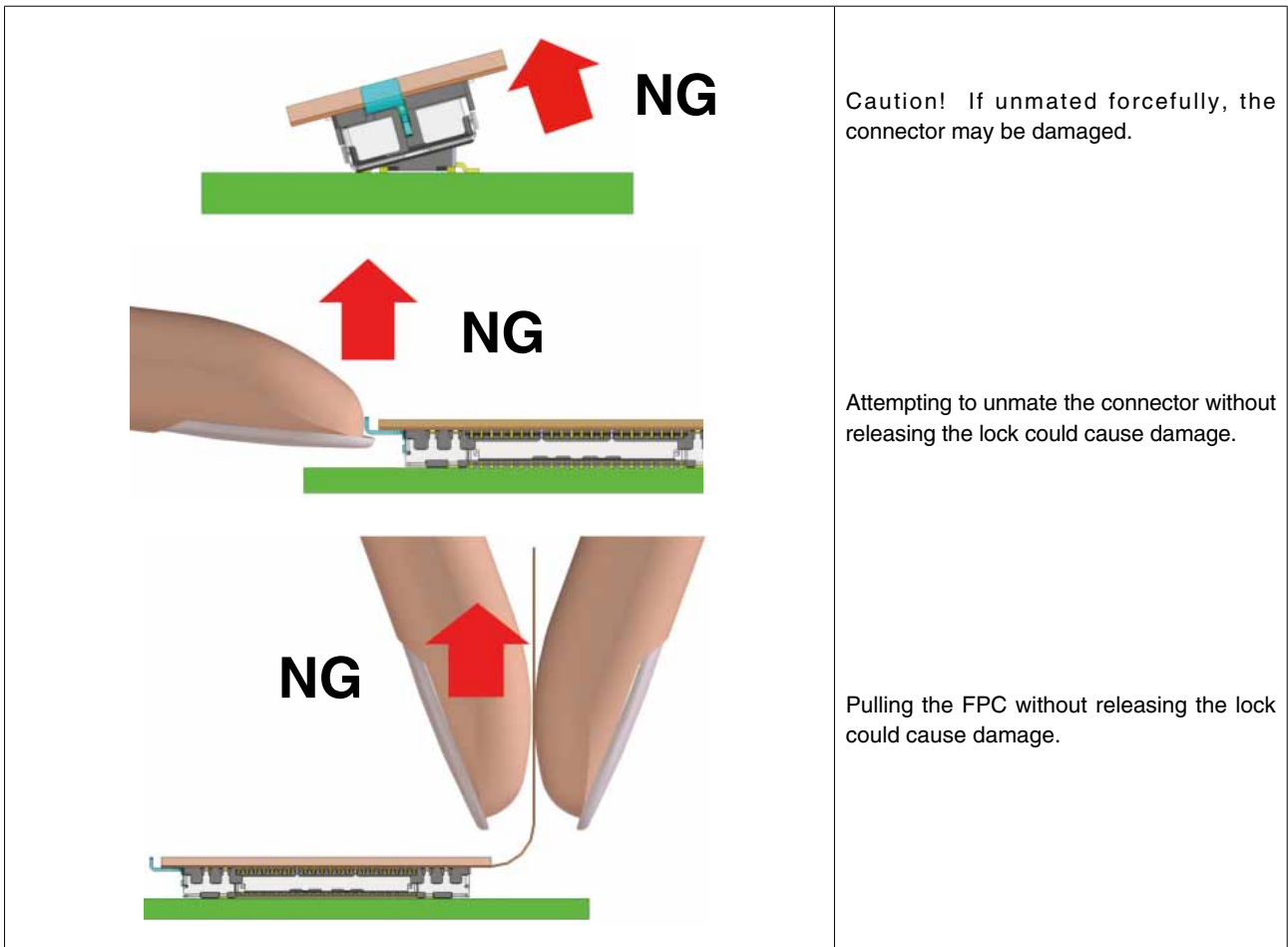

Caution! If unmated forcefully, the connector may be damaged.

Attempting to unmate the connector without releasing the lock could cause damage.

Pulling the FPC without releasing the lock could cause damage.

● PCB layout

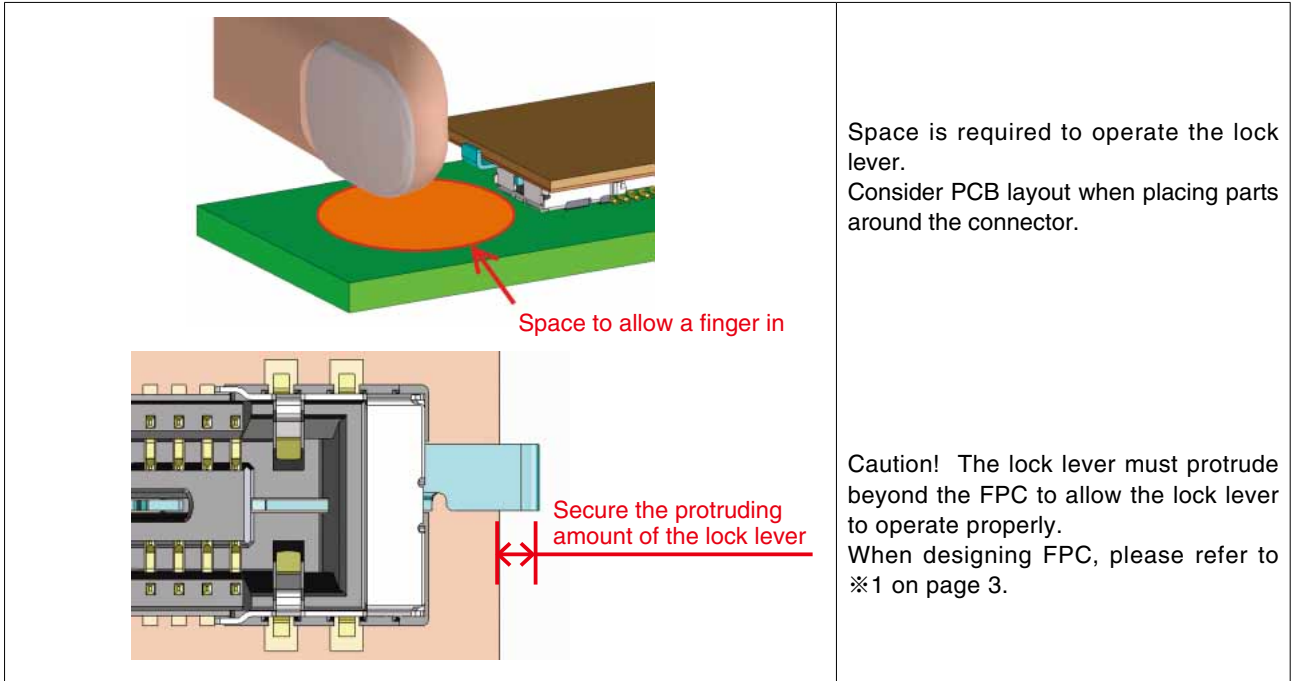

Space is required to operate the lock lever. Consider PCB layout when placing parts around the connector.

Caution! The lock lever must protrude beyond the FPC to allow the lock lever to operate properly. When designing FPC, please refer to ※1 on page 3.



HIROSE ELECTRIC CO.,LTD.

2-6-3,Nakagawa Chuoh,Tsuzuki-Ku,Yokohama-Shi 224-8540,JAPAN
 TEL: +81-45-620-3526 Fax: +81-45-591-3726
<http://www.hirose.com>
<http://www.hirose-connectors.com>