

GT16 Series

— Subminiature Connectors for coaxial cables —

<In-line and board mounted.>

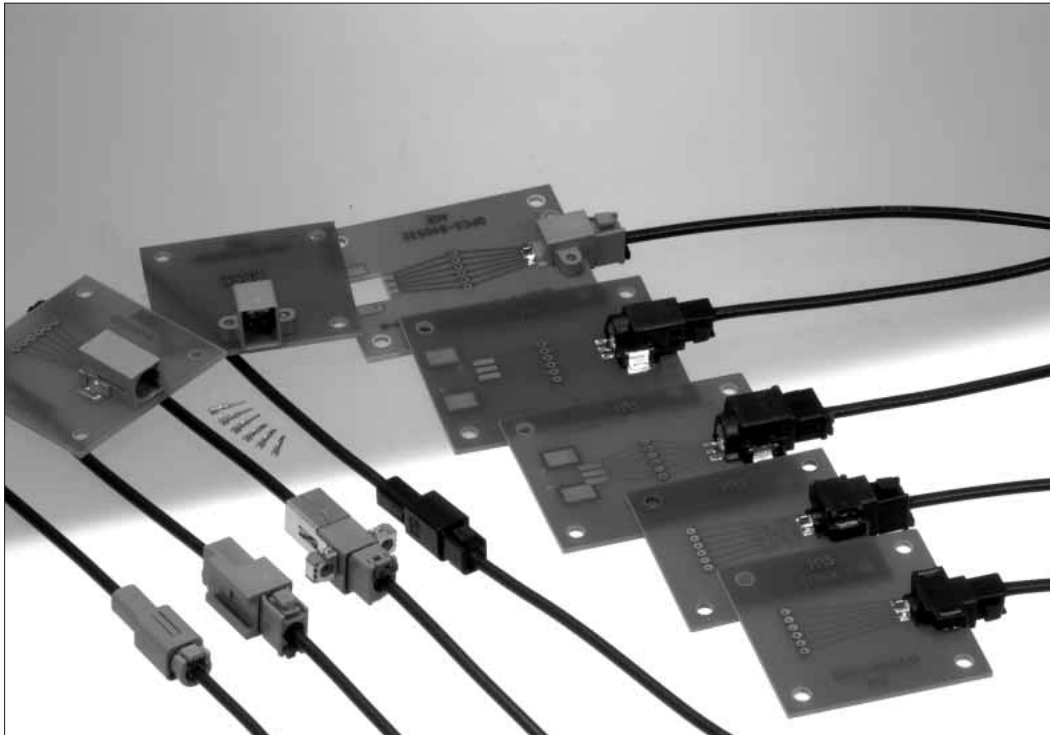

■ Features

- **Space-saving design**
Compact and light comparing to HRS GT5 series.
- **Excellent high frequency performance**
Refer to V.S.W.R. data on the following pages.

■ Applications

In-car communication, car sensors(temperature, pressure), automotive audio systems, GPS antenna systems, RACS antenna audio/video antenna systems, CRT displays, medical and measuring instrumentation LAN systems.

GT16 Series

F Connectors (Common Use)

● Center terminal

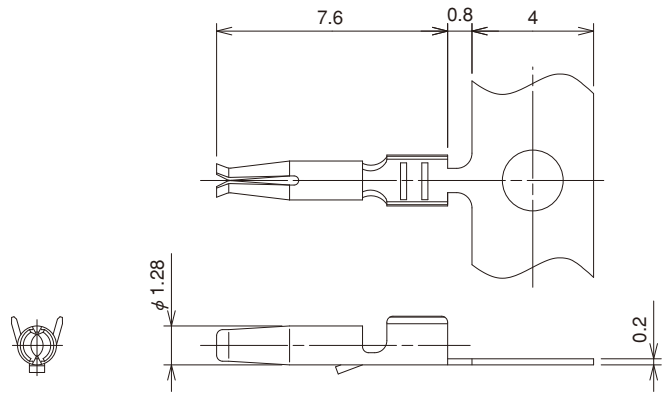

Part No.	HRS No.	Material/Plating	Conductor Size	Packaging	RoHS
GT16-2428SCF	766-0001-2	Phosphor bronze/ Tin plating	24 to 28 AWG	10,000 pcs/reel	YES
GT16-30SCF	766-0055-1		30 AWG		

● Insulator (Common Use)

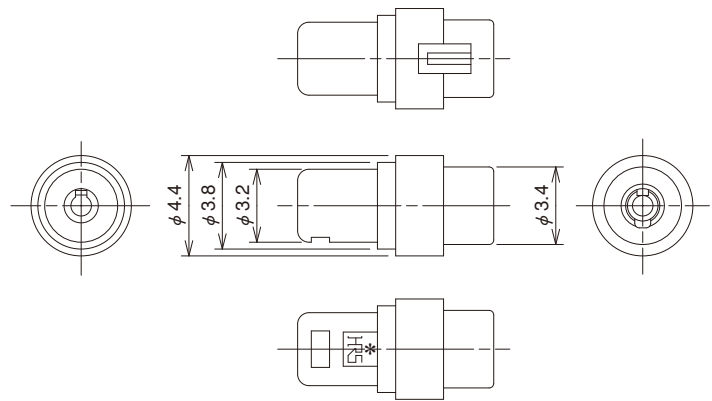

Part No.	HRS No.	Material	Color	Packaging	RoHS
GT16-SC	766-0002-5	PBT	White	1	YES

M Connectors (Common Use)

● Center Terminals

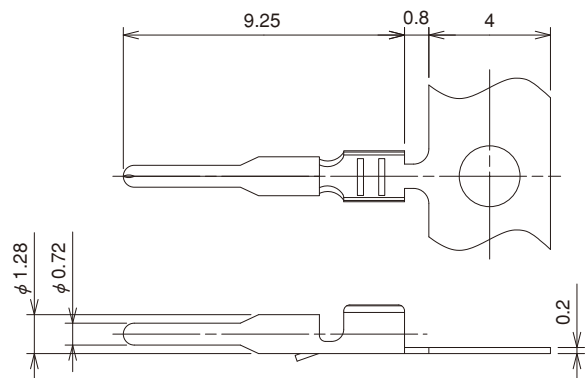

Part No.	HRS No.	Material/Plating	Conductor Size	Packaging	RoHS
GT16-2428PCF	766-0006-6	Brass/Tin plating	24 to 28 AWG	10,000 pcs/reel	YES
GT16-30PCF	766-0015-7		30 AWG		

For Antenna

- GT5
- GT13
- GT16**
- PO5G
- GT19
- GT21
- GT26
- GT36
- GT11
- GT17
- GT32
- GT3
- GT7
- GT10
- GT18W
- GT25
- GT8E
- GT9
- GT15

Feb.1.2019 Copyright 2019 HIROSE ELECTRIC CO., LTD. All Rights Reserved. For Antenna

- GT5
- GT13
- GT16**
- PO5G
- GT19
- GT21
- GT26
- GT36
- GT11
- GT17
- GT32
- GT3
- GT7
- GT10
- GT18W
- GT25
- GT8E
- GT9
- GT15

● Insulator (Common Use)

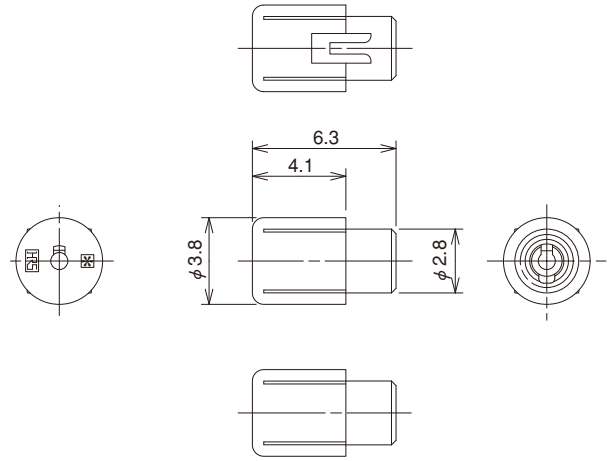

Part No.	HRS No.	Material	Color	Packaging	RoHS
GT16-PC	766-0007-9	PBT	White	1	YES

■ Without retainer type (F Connector)

● Housing

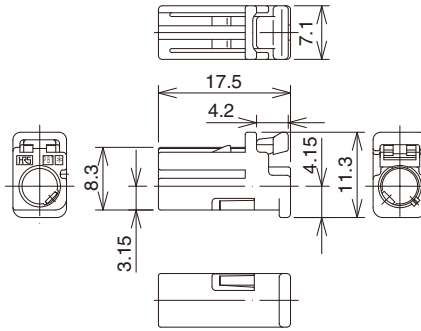

Part No.	HRS No.	Material	Color	Packaging	RoHS
GT16F-1S-HU(A)	766-0082-4	PBT	Brown	1	YES
GT16F-1S-HU(B)	766-0083-7		Green		

● Outer terminal

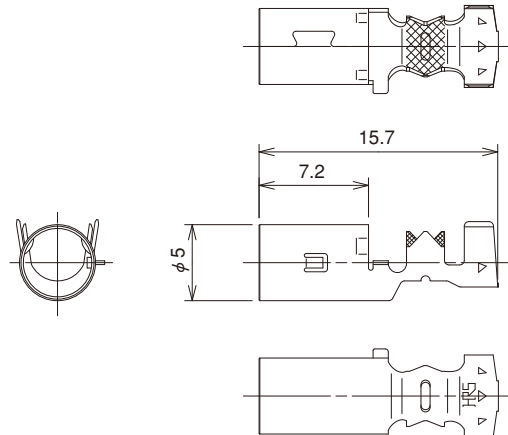
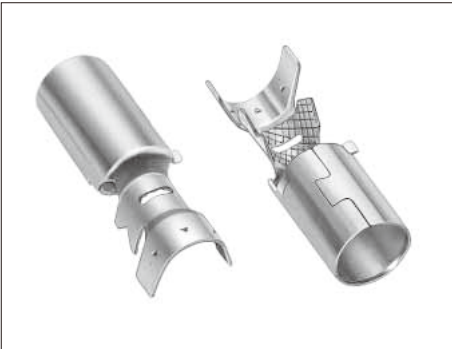

Part No.	HRS No.	Material/Plating	Insulator Diameter	Outer Diameter	Packaging	RoHS
GT16-/1.6-2.9SC	766-0003-8	Phosphor bronze/ Tin plating	ϕ 1.5 to 2.0	ϕ 2.6 to 3.4	1	YES
GT16-/0.7-1.5SC	766-0056-4		ϕ 0.6 to 0.9	ϕ 1.4 to 1.8		

For Antenna

GT5
GT13
GT16
PO5G
GT19
GT21
GT26
GT36
GT11
GT17
GT32
GT3
GT7
GT10
GT18W
GT25
GT8E
GT9
GT15

Without retainer type (M Connector)

● Housing

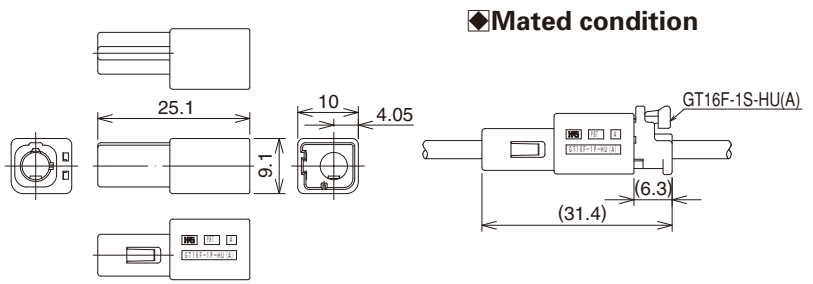

Part No.	HRS No.	Material	Color	Packaging	RoHS
GT16F-1P-HU(A)	766-0086-5	PBT	Brown	1	YES
GT16F-1P-HU(B)	766-0087-8		Green		

● Outer terminals

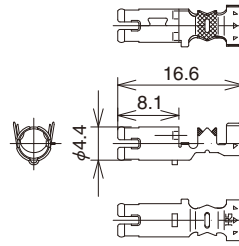

Part No.	HRS No.	Material	Plating	Insulator Diameter	Outer Diameter	Packaging	RoHS
GT16C-/1.6-2.9PC	766-0019-8	Phosphor bronze	Tin plating	φ1.5 to 2.0	φ2.6 to 3.4	1	YES
GT16C-/0.7-1.5PC	766-0018-5			φ0.6 to 0.9	φ1.4 to 1.8		

● Printed Circuit Board Type (SMT Type)

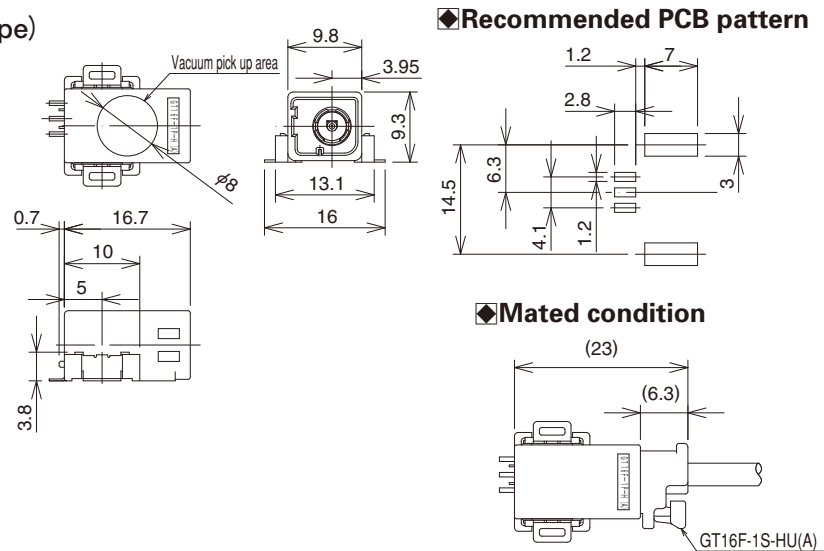

Part No.	HRS No.	Material/Plating	Color	Packaging	RoHS
GT16F-1P-H(A)	766-0078-7	Housing : PPS Inner Terminal : Phosphor bronze/Tin plating Outer Terminal : Phosphor bronze/Tin plating Insulator : PPS/Natural	Brown	1	YES
GT16F-1P-H(B)	766-0079-0	Shield plate : Phosphor bronze/Tin plating Metal reinforcement : Brass/Tin plating	Green		

■ Genuine Market Parts F Connectors

● Housing (Retainer Stopper Specification)

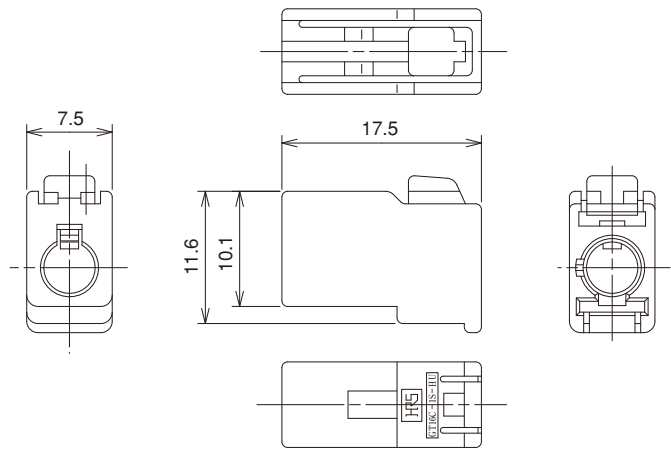

Part No.	HRS No.	Material	Color	Packaging	RoHS
GT16C-1S-HU	766-0010-3	PBT	Light Gray	1	YES
GT16C-1S-HU(A)	766-0060-1		Brown		
GT16C-1S-HU(B)	766-0061-4		Green		

Note : This product is used in conjunction with retainer GT16C-1P/S-R (CL766-0011-6) which is a separate item.

● Outer terminal (Retainer Stopper Specification)

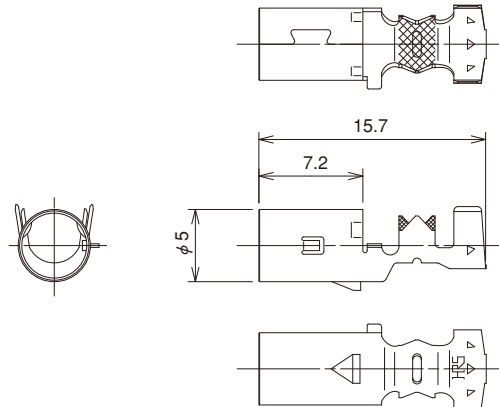
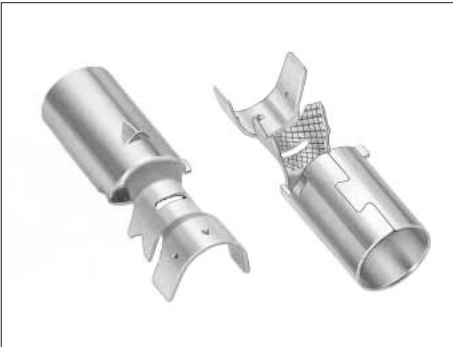

Part No.	HRS No.	Material/Plating	Insulator Diameter	Outer Diameter	Packaging	RoHS
GT16C-/1.6-2.9SC	766-0012-9	Phosphor bronze/ Tin plating	φ1.5 to 2.0	φ2.6 to 3.4	1	YES
GT16C-/0.7-1.5SC	766-0057-7		φ0.6 to 0.9	φ1.4 to 1.8		

● Retainer

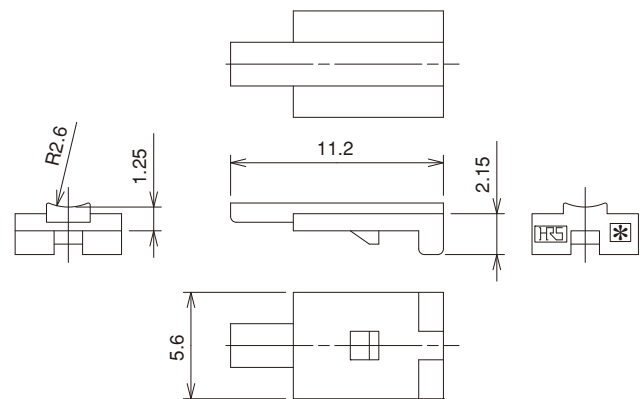

Part No.	HRS No.	Material	Color	Packaging	RoHS
GT16C-1P/S-R	766-0011-6	PBT	Dark Gray	1	YES

■ Genuine Market Parts M Connectors

● Housing (Retainer Stopper Specification)

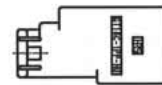
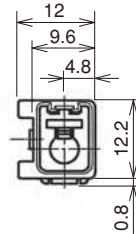
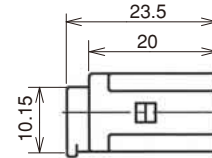
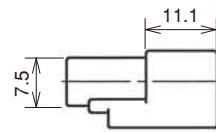
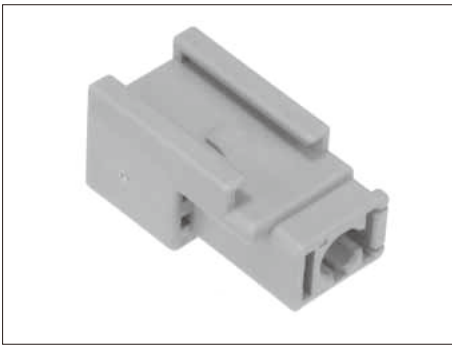

◆ Mated condition

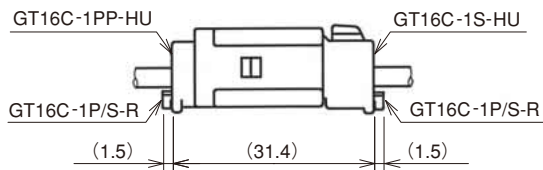

Part No.	HRS No.	Material	Color	Packaging	RoHS
GT16C-1PP-HU	766-0029-1	PBT	Light Gray	1	YES
GT16C-1PP-HU(A)	766-0064-2		Brown		
GT16C-1PP-HU(B)	766-0065-5		Green		

Note: Use this product with separate retainer part GT16C-1P/S-R(CL766-0011-6).

● Printed Circuit Board Type (Reinforced Lock and Screw Fastening Type)

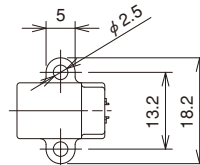

◆ Recommended panel cutout dimension

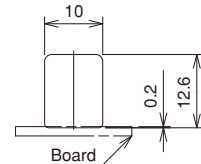

◆ Mated condition

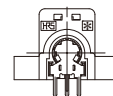
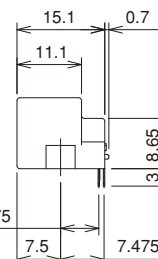
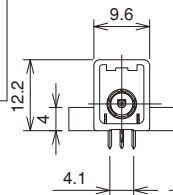
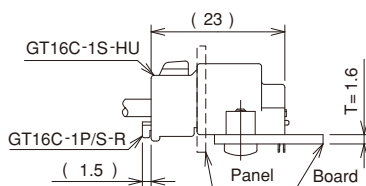

◆ Recommended PCB pattern

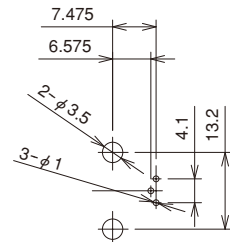

Part No.	HRS No.	Material/Plating	Color	Packaging	RoHS
GT16C-1P-DS	766-0013-1	Housing : PBT	Light Gray	1	YES
GT16C-1P-DS(A)	766-0062-7	Inner Terminal : Phosphor bronze/Tin plating Insulator : Phosphor bronze/Tin plating	Brown		
GT16C-1P-DS(B)	766-0063-0	Insulator : PPS/Natural Shield plate : Phosphor bronze/Tin plating	Green		

Note : Use mounting screws of M3 with nominal diameter 3L-6.

● Panel Mounting Type

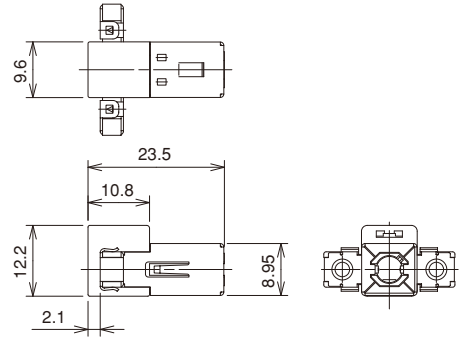
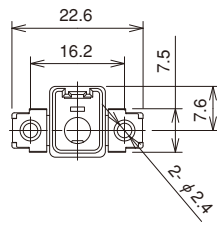
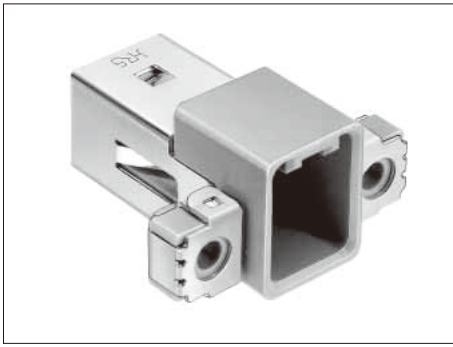

◆ Mated condition

◆ Recommended panel cutout dimension

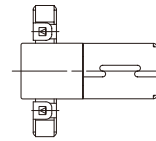
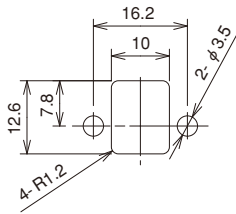
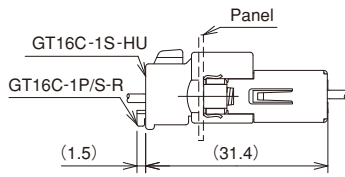

Part No.	HRS No.	Material/Plating or Color	Packaging	RoHS
GT16CB-1PP-HU	766-0017-2	Housing : PBT/Light Gray Ground terminal : Copper alloy/Tin plating	1	YES

Note : Use mounting screws of M3 with nominal diameter 3L-6.

◆GT16C Wiring Method

1. Pass the cable through the outside tube.

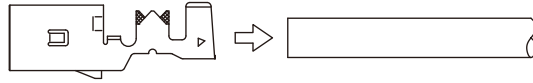

2. Strip the cable.

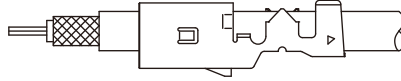

3. Crimp the center terminal.

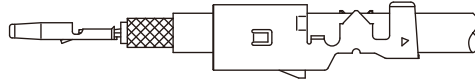

4. Insert the crimped terminal into the Insulator.

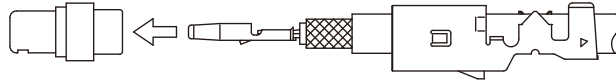

5. Insert the insulator into the outside tube.

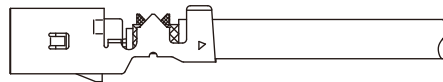

6. Crimp the outside tube.

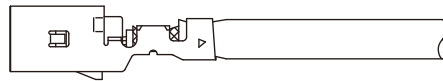

7. Insert outer terminal block into the housing.

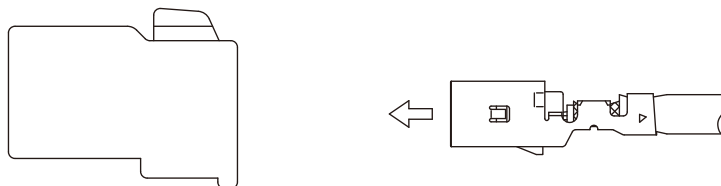

8. Insert the retainer into the housing.

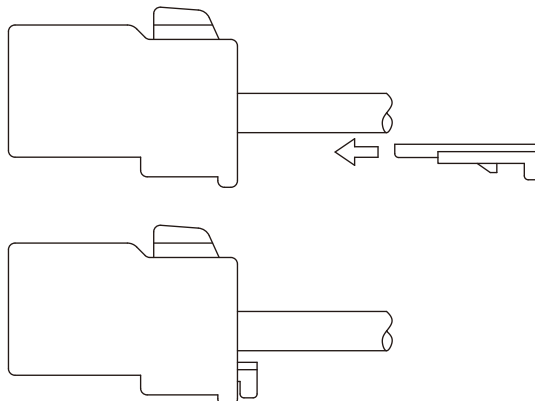

◆ F Connector Components Table

Inner Terminal	Insulator	Outer Terminal	Housing	Retainer
GT16-2428SCF GT16-30SCF	GT16-SC	GT16-/1.6-2.9SC	GT16F-1S-HU (A)	Not Used
		GT16-/0.7-1.5SC	GT16F-1S-HU (B)	
		GT16C-/1.6-2.9SC	GT16C-1S-HU	GT16C-1P/S-R
		GT16C-/0.7-1.5SC	GT16C-1S-HU (A) GT16C-1S-HU (B)	

◆ Mating Table

F Connectors	M Connectors
GT16C-1S-HU	GT16CB-1PP-HU
	GT16C-1PP-HU
	GT16C-1P-DS

◆ M Connector Components Table

Inner Terminal	Insulator	Outer Terminal	Housing	Retainer
GT16-2428PCF GT16-30PCF	GT16-PC	GT16C-/1.6-2.9PC GT16C-/0.7-1.5PC	GT16CB-1PP-HU	Not Used
			GT16F-1P-HU (A)	
			GT16F-1P-HU (B)	GT16C-1P/S-R
			GT16C-1PP-HU	
			GT16C-1PP-HU (A)	
			GT16C-1PP-HU (B)	

Printed Circuit Board Type
GT16F-1P-H (A)
GT16F-1P-H (B)
GT16C-1P-DS
GT16C-1P-DS (A)
GT16C-1P-DS (B)

◆ Key Variation

F Connectors	M Connectors
GT16F-1S-HU (A)	GT16F-1P-HU(A)
	GT16F-1P-H(A)
GT16F-1S-HU (B)	GT16F-1P-HU(B)
	GT16F-1P-H(B)
GT16C-1S-HU (A)	GT16C-1P-HU(A)
	GT16C-1P-DS(A)
GT16C-1S-HU (B)	GT16C-1P-HU(B)
	GT16C-1P-DS(B)

◆ Crimping tools

User's manuals are available. Please ask your Hirose Electric account representative.

Automatic Crimping Machine



Picture reference only

Part No. CM-105C

* See the table below for the product number of the applicator.

Specifications

Item	Specification	Remarks
Press capacity	1.5ton	
Stroke Length	30mm	
Number of strokes	200spm (50Hz)	240spm (60Hz)
Weight	75kg	
Motor	0.2kW	AC100V
Crimping speed	2,000~4,000/H	

Hand Press

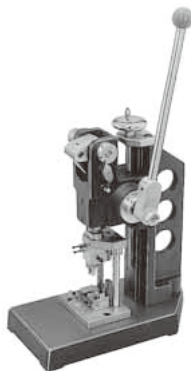

● Harness Tool

Terminal Product No.	Terminal HRS No.	Tool No.	Tool HRS No.
GT16-2428SCF	766-0001-2	AP105-GT16-2428	901-5108-4
GT16-2428PCF	766-0006-6		
GT16-30SCF	766-0055-1	AP105-GT16-30	901-5124-0
GT16-30PCF	766-0015-7		
GT16-/1.6-2.9SC	766-0003-8	GT16-1.6-2.9/CK-MP	902-5058-4
GT16C-/1.6-2.9SC	766-0012-9		
GT16C-/1.6-2.9PC	766-0019-8		
GT16-/0.7-1.5SC	766-0056-4	GT16-0.7-1.5/CK-MP	902-5064-7
GT16C-/0.7-1.5SC	766-0057-7		
GT16C-/0.7-1.5PC	766-0018-5		

* Crimp height setting tables are available for each cable type. Please contact your nearest Hirose Electric account representative.
Different cables will require different crimp height settings.

GT16G Series

F and M Common Parts

● Terminal Ferrule

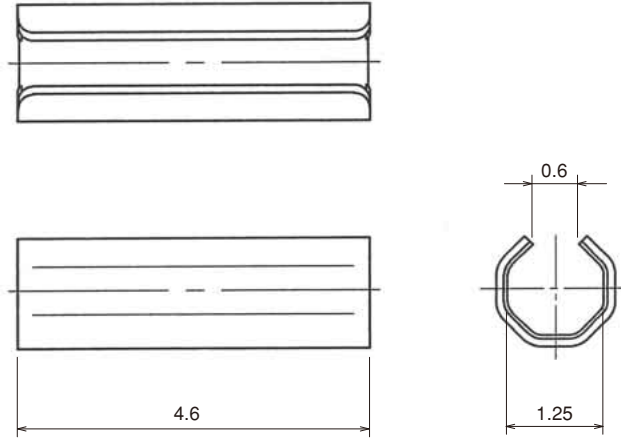

Part No.	HRS No.	Material	Plating	Packaging	RoHS
GT16G-FR	766-0028-9	Phosphor bronze	Tin plating	1	YES

F and M Common Parts

● Outer Ferrule

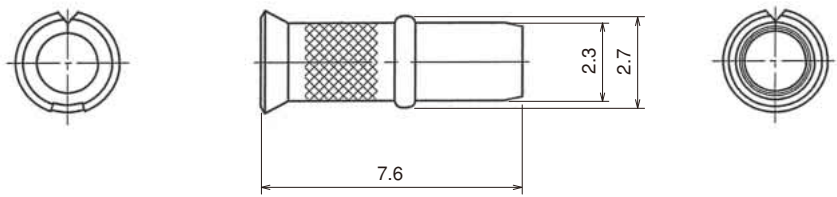

Part No.	HRS No.	Material	Plating	Packaging	RoHS
GT16G-1.5DHQS	766-0027-6	Phosphor bronze	Tin plating	1	YES

F Common Parts

● Center Terminal

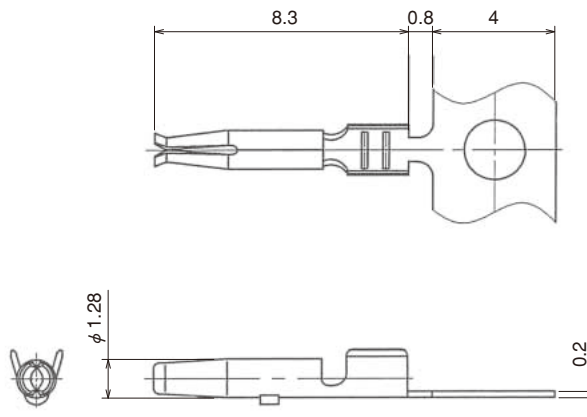

Part No.	HRS No.	Material	Plating	Conductor Size	Packaging	RoHS
GT16G-2428SCF	766-0022-2	Phosphor bronze	Tin plating	24 to 28 AWG	10,000 pcs/reel	YES

Feb.1.2019 Copyright 2019 HIROSE ELECTRIC CO., LTD. All Rights Reserved.

For Antenna

- GT5
- GT13
- GT16**
- PO5G
- GT19
- GT21
- GT26
- GT36
- GT11
- GT17
- GT32
- GT3
- GT7
- GT10
- GT18W
- GT25
- GT8E
- GT9
- GT15

Feb.1.2019 Copyright 2019 HIROSE ELECTRIC CO., LTD. All Rights Reserved for Antenna

- GT5
- GT13
- GT16**
- PO5G
- GT19
- GT21
- GT26
- GT36
- GT11
- GT17
- GT32
- GT3
- GT7
- GT10
- GT18W
- GT25
- GT8E
- GT9
- GT15

● Insulator

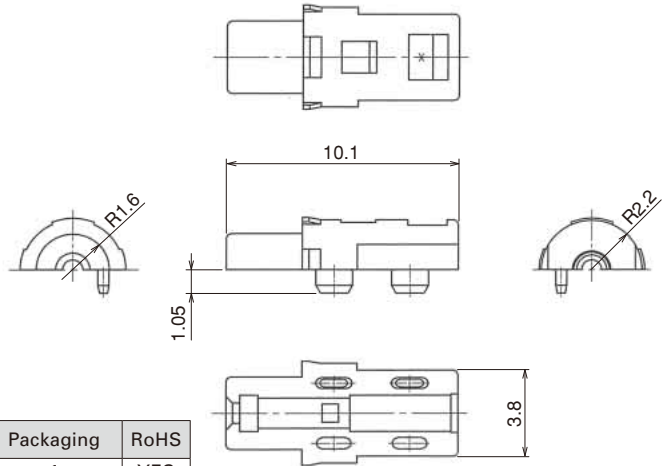

Part No.	HRS No.	Material	Color	Packaging	RoHS
GT16G-SC	766-0023-5	PBT	Natural	1	YES

Note : Two of these products are used per connection.

M Common Parts

● Center Terminal

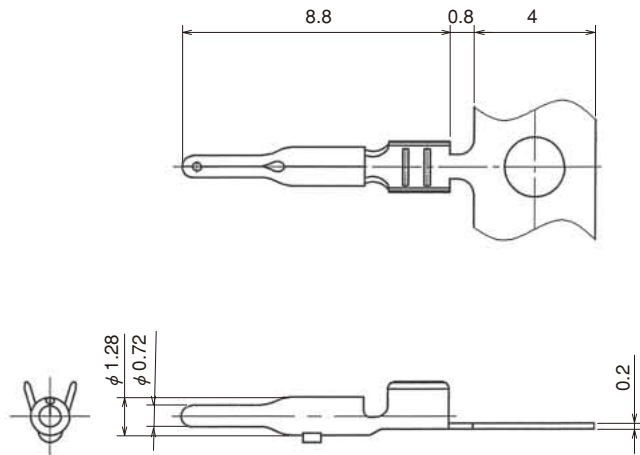

Part No.	HRS No.	Material	Plating	Conductor Size(AWG)	Packaging	RoHS
GT16G-2428PCF	766-0046-0	Brass	Tin plating	24 to 28 AWG	10,000 pcs/reel	YES

● Insulator

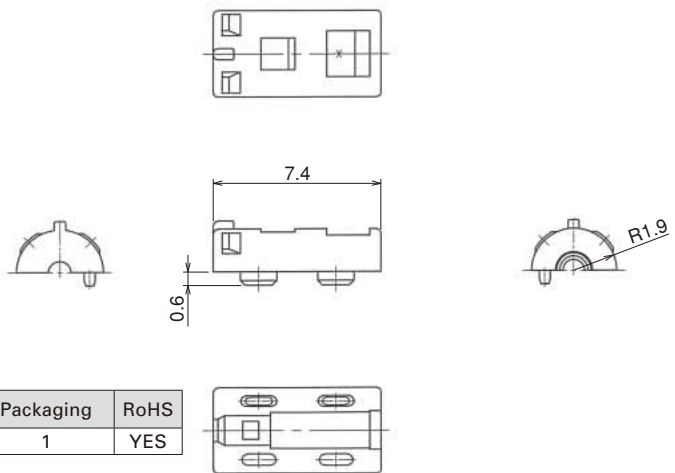
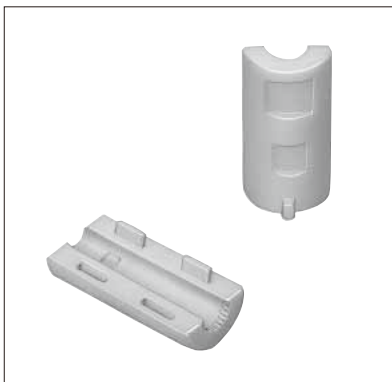

Part No.	HRS No.	Material	Color	Packaging	RoHS
GT16G-PC	766-0047-3	PBT	Natural	1	YES

Note : Two of these products are used per connection.

● Outer Terminal

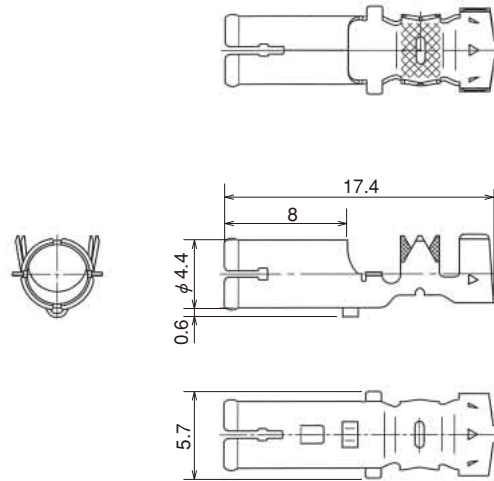

Part No.	HRS No.	Material	Plating	Applicable cable	Packaging	RoHS
GT16G-/1.6-2.9PC	766-0048-6	Phosphor bronze	Tin plating	1.5D-2W or equivalent	1	YES

■ F Connector (No retainer required type)

● Housing

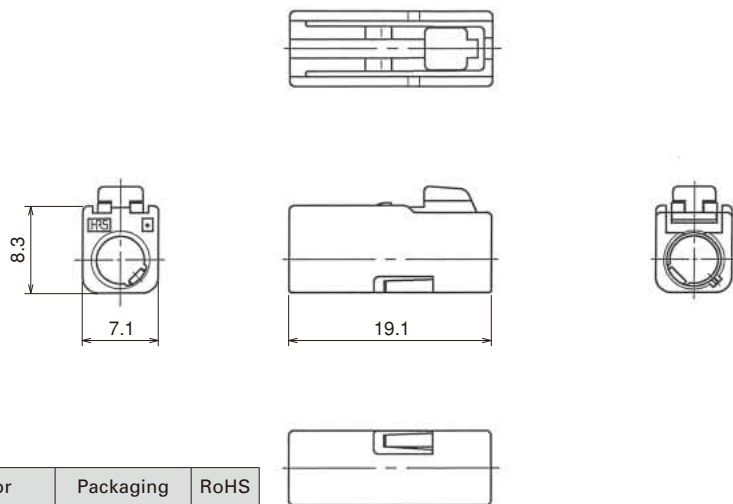

Part No.	HRS No.	Material	Color	Packaging	RoHS
GT16GM-1S-HU	766-0033-9	PBT	Black	1	YES

● Outer Terminal

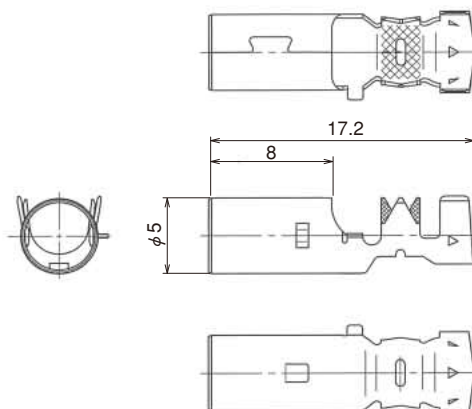

Part No.	HRS No.	Material	Plating	Applicable cable	Packaging	RoHS
GT16GM-/1.6-2.9SC	766-0025-0	Phosphor bronze	Tin plating	1.5D-2W or equivalent	1	YES

For Antenna

- GT5
- GT13
- GT16**
- PO5G
- GT19
- GT21
- GT26
- GT36
- GT11
- GT17
- GT32
- GT3
- GT7
- GT10
- GT18W
- GT25
- GT8E
- GT9
- GT15

Feb.1.2019 Copyright 2019 HIROSE ELECTRIC CO., LTD. All Rights Reserved for Antenna

- GT5
- GT13
- GT16**
- PO5G
- GT19
- GT21
- GT26
- GT36
- GT11
- GT17
- GT32
- GT3
- GT7
- GT10
- GT18W
- GT25
- GT8E
- GT9
- GT15

■ M Connector (No retainer required type)

● Housing

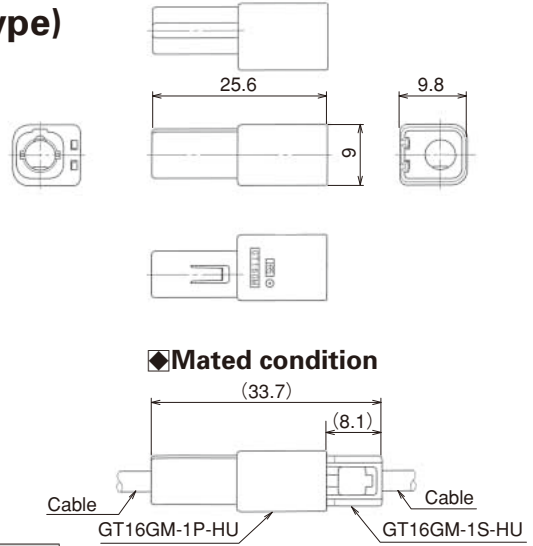

Part No.	HRS No.	Material	Color	Packaging	RoHS
GT16GM-1P-HU	766-0050-8	PBT	Black	1	YES

● Housing (Bracket mounting type)

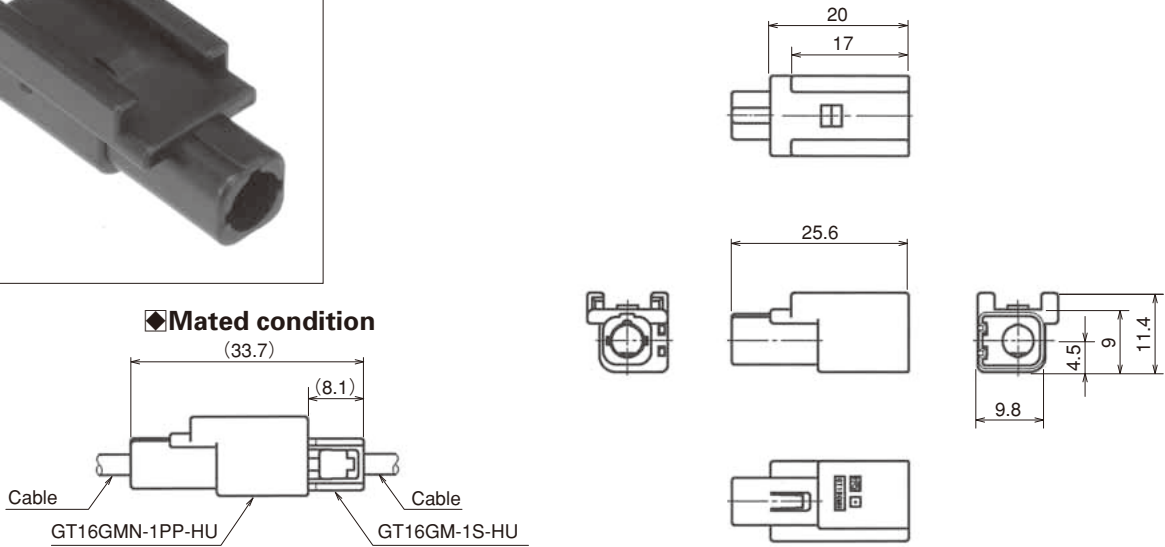

Part No.	HRS No.	Material	Color	Packaging	RoHS
GT16GMN-1PP-HU	766-0051-0	PBT	Black	1	YES

● Board Type (Lock Pin Type)

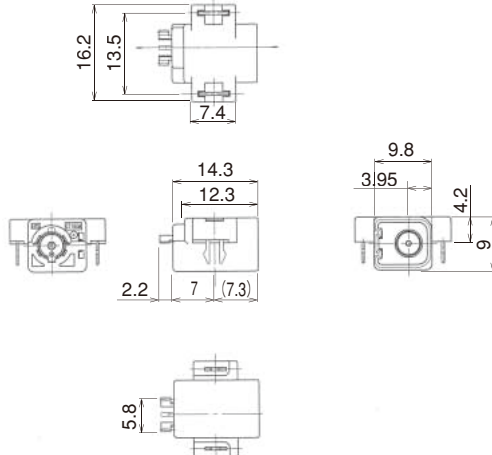

◆ Recommended panel cutout dimension

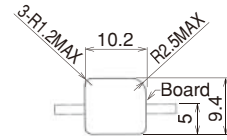

◆ Mated condition

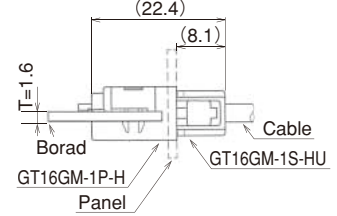

◆ Recommended PCB pattern

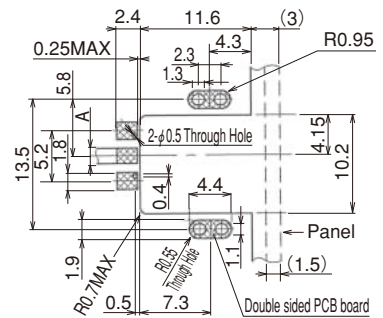

* Use micro strip line and set so that dimension A has a characteristic impedance of 50Ω.

Part No.	HRS No.	Material/Plating or Color	Packaging	RoHS
GT16GM-1P-H	766-0032-6	Housing : PBT/Black Inner Terminal : Phosphor bronze/Tin plating Outer Terminal : Phosphor bronze/Tin plating Insulator : PBT/Natural Lock pin : Phosphor bronze/Tin plating	1	YES

● Board Type (SMT Type)

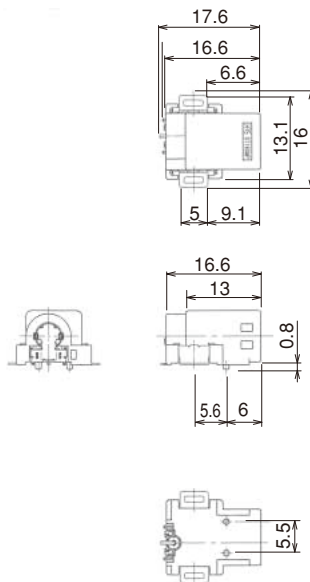

◆ Mated condition

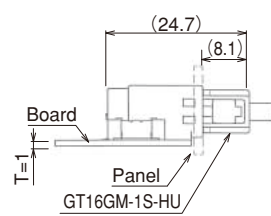

◆ Recommended panel cutout dimension

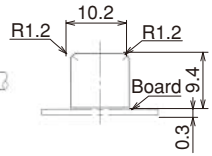

◆ Recommended PCB pattern

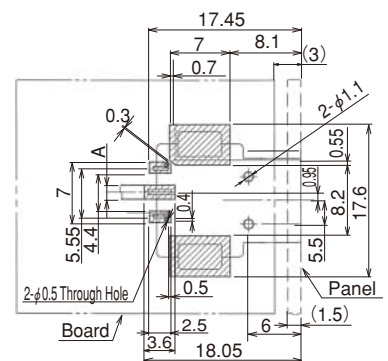

* Use micro strip line and set so that dimension A has a characteristic impedance of 50Ω.

Part No.	HRS No.	Material/Plating or Color	Packaging	RoHS
GT16GMP-1P-H	766-0052-3	Housing : PPS/Black Inner Terminal : Phosphor bronze/Tin plating Outer Terminal : Phosphor bronze/Tin plating Insulator L,R : PPS/Natural Shield plate : Phosphor bronze/Tin plating Metal fittings : Brass/Tin plating	200 pcs/reel	YES

Feb.1.2019 Copyright 2019 HIROSE ELECTRIC CO., LTD. All Rights Reserved for Antenna

- GT5
- GT13
- GT16**
- PO5G
- GT19
- GT21
- GT26
- GT36
- GT11
- GT17
- GT32
- GT3
- GT7
- GT10
- GT18W
- GT25
- GT8E
- GT9
- GT15

■ F Connector (Retainer required type)

● Housings

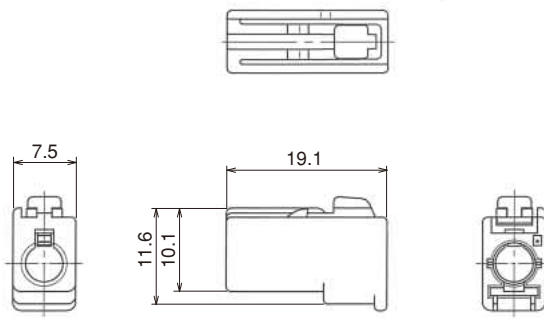

Part No.	HRS No.	Material	Color	Packaging	RoHS
GT16G-1S-HU	766-0026-3	PBT	Light Gray	1	YES
GT16G-1S-HU(24)	766-0026-3 24		Black		

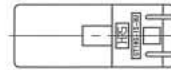

Note : Use this product with separate retainer part GT16C-1P/S-R (CL766-0011-6).

● Outer Terminal

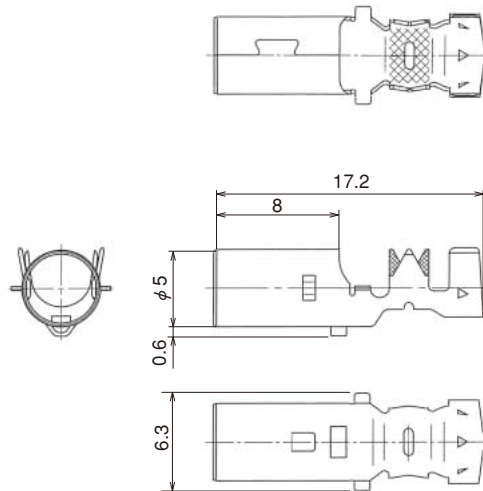

Part No.	HRS No.	Material	Plating	Applicable cable	Packaging	RoHS
GT16G-/1.6-2.9SC	766-0024-8	Phosphor bronze	Tin plating	1.5D-2W or equivalent	1	YES

■ Genuine Market Parts M Connectors

● Board Type (Screw Fastening Type)

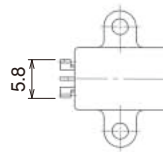
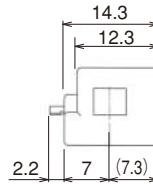
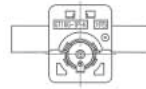
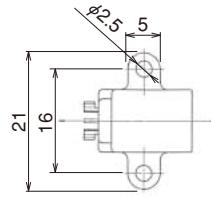

◆ Mated condition

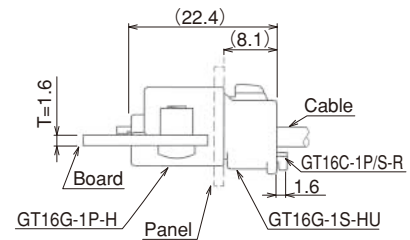

◆ Recommended panel cutout dimension

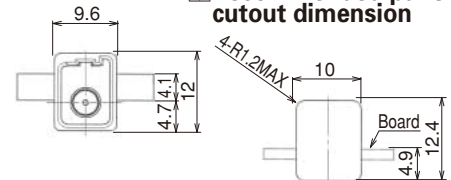

◆ Recommended PCB pattern

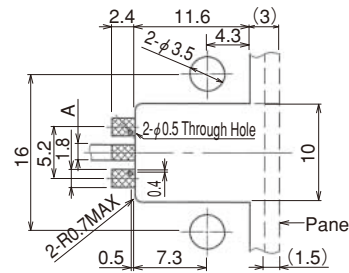

Part No.	HRS No.	Material/Plating or Color	Packaging	RoHS
GT16G-1P-H	766-0021-0	Housing : PBT/Light Gray Inner Terminal : Phosphor bronze/Tin plating Outer Terminal : Phosphor bronze/Tin plating Insulator : PBT/Natural	1	YES

Note 1: Suitable mounting screws are JIS B 1122 pan head tapping screws class 2, nominal diameter 3, length 6.

Note 2: Use micro strip line and set so that dimension A has a characteristic impedance of 50Ω.

● Board Type (SMT Type)

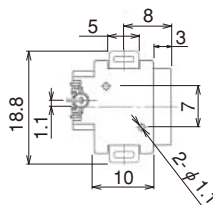
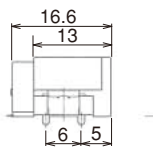
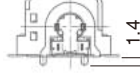
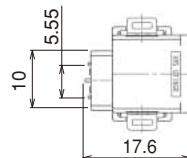

◆ Mated condition

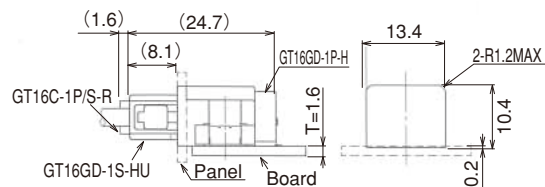

◆ Recommended panel cutout dimension

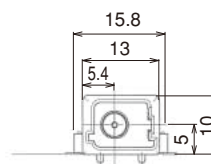

◆ Recommended PCB pattern

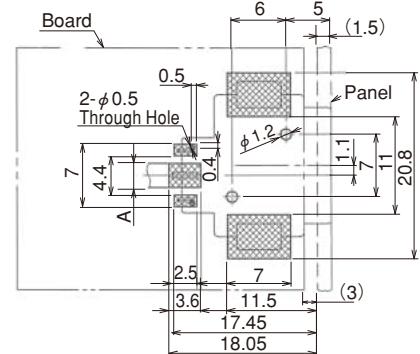

Part No.	HRS No.	Material/Plating or Color	Packaging	RoHS
GT16GD-1P-H	766-0044-5	Housing : PPS/Black Inner Terminal : Phosphor bronze/Tin plating Outer Terminal : Phosphor bronze/Tin plating Insulator L,R : PPS/Natural Shield plate : Phosphor bronze/Tin plating Metal reinforcement : Brass/Tin plating	200 pcs/reel	YES

Note : Use micro strip line and set so that dimension A has a characteristic impedance of 50Ω.

- GT5
- GT13
- GT16**
- PO5G
- GT19
- GT21
- GT26
- GT36
- GT11
- GT17
- GT32
- GT3
- GT7
- GT10
- GT18W
- GT25
- GT8E
- GT9
- GT15

● Board Type (Lead Reflow Type)

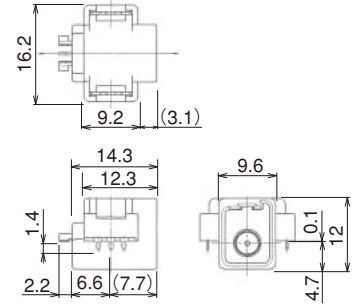

◆ Recommended panel cutout dimension

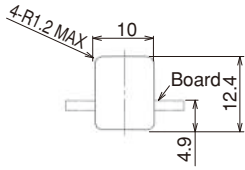

◆ Mated condition

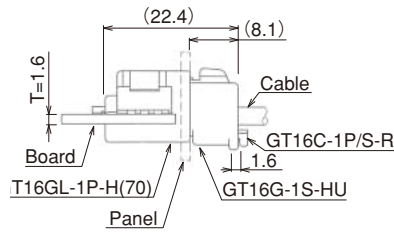

◆ Recommended PCB pattern

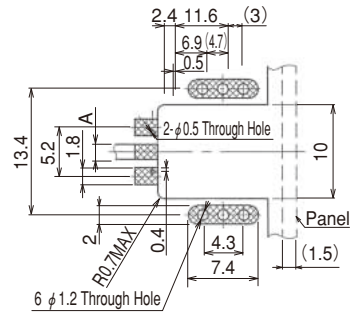

Part No.	HRS No.	Material/Plating	Color	Packaging	RoHS
GT16GL-1P-H(70)	766-0043-2 70	Housing : PPS Inner Terminal : Phosphor bronze/Tin plating Outer Terminal :	Light Gray	200 pcs/reel	YES
GT16GL-1P-H(71)	766-0043-2 71	Phosphor bronze/Tin plating Insulator : PBT/Natural Metal reinforcement : Brass/Tin plating	Black		

Note : Use micro strip line and set so that dimension A has a characteristic impedance of 50Ω.

● Board Type (Lock Pin Type)



◆ Recommended panel cutout dimension

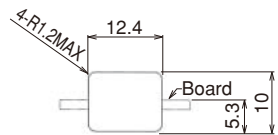

◆ Mated condition

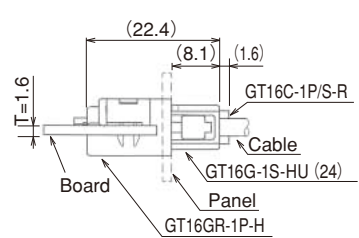

◆ Recommended PCB pattern

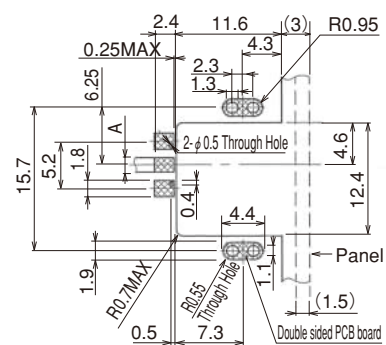

Part No.	HRS No.	Material/Plating or Color	Packaging	RoHS
GT16GR-1P-H	766-0059-2	Housing : PBT/Black Inner Terminal : Phosphor bronze/Tin plating Outer Terminal : Phosphor bronze/Tin plating Insulator : PBT/Natural Lock pin : Phosphor bronze/Tin plating	1	YES

Note : Use micro strip line and set so that dimension A has a characteristic impedance of 50Ω.

For Antenna

- GT5
- GT13
- GT16**
- PO5G
- GT19
- GT21
- GT26
- GT36
- GT11
- GT17
- GT32
- GT3
- GT7
- GT10
- GT18W
- GT25
- GT8E
- GT9
- GT15

■ F Connector (Waterproof type)

● Housing

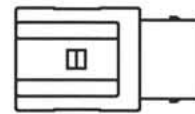
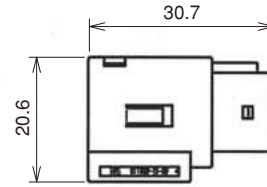
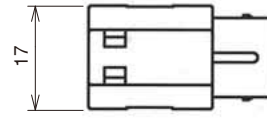

◆ Mated condition

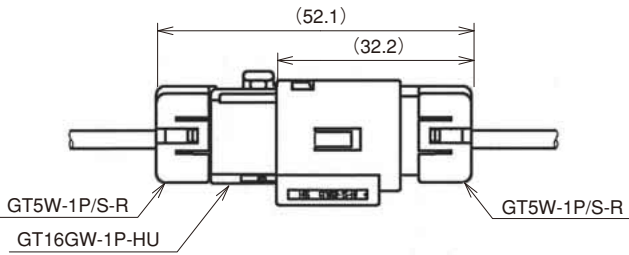

Part No.	HRS No.	Material	Color	Packaging	RoHS
GT16GW-1S-HU	766-0076-1	PBT	Black	1	YES
		Silicon rubber	White		

Note: Assemble main parts with separated retainer part GT5W-1P/S-R (CL755-0028-5).

■ M Connector (Waterproof type)

● Housing

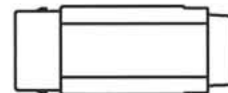
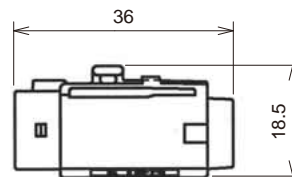
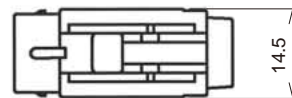

Part No.	HRS No.	Material	Color	Packaging	RoHS
GT16GW-1P-HU	766-0077-4	PBT	Black	1	YES

Note: Assemble main parts with separate retainer part GT5W-1P/S-R (CL755-0028-5).

◆ GT16G Wiring Method

① Strip the cable.

- Note 1. See "Crimping Quality Standards Manual" for information about the end processing dimensions.
- Note 2. Before performing end processing, arrange cable ends to be perpendicular. (There shall be no cable crushing.)
- Note 3. Care must be taken so as not to damage the various cut portions of the center conductor, dielectric, and outer conductor.

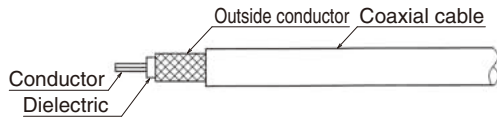

② Crimp the center terminal with the special jig.

- Note 1. See "Crimping Conditions Table" for information about the crimp height.
- Note 2. See "Crimping Quality Standards Manual" for information about crimping standards.

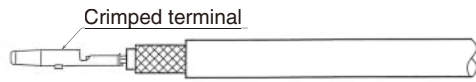

③ Place the outside tube over the cable.

- Note 1. Pay attention to the placement direction of the outside tube.

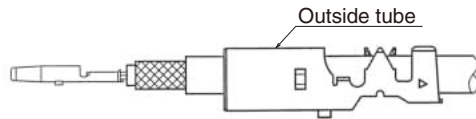

④ Widen the external conductor with the special tool, place the outer ferrule, and return the external conductor over the outer ferrule.

- Note 1. Spread only the outer conductor without unravelling. Copper foil or aluminum foil shall not be spread, but shall be on the inside of the outer ferrule.
- Note 2. The orientation of the outer ferrule shall be as indicated in the diagram. Align the slit of the outer ferrule with the protruding portion of the crimp terminal and insert.
- Note 3. The outer ferrule shall be placed so that the portion of different level is inserted as far as the sheath end.
- Note 4. Pay attention to pinching of the external conductor (i.e., biting into the sheath) during the placement.

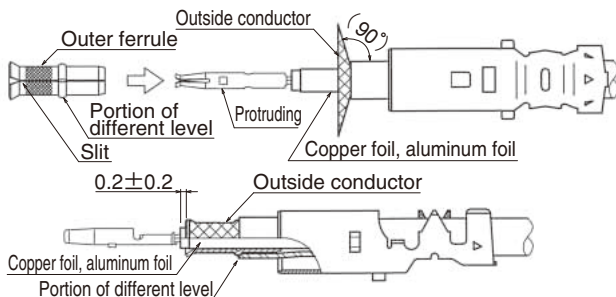

⑤ Using the special jig, insert the terminal ferrule from the coupling side of the crimp terminal until it reaches the end.

- Note 1. Orient the terminal ferrule as illustrated in the diagram, align the slit portion of the terminal ferrule with the protruding portion of the crimp terminal, and then insert.

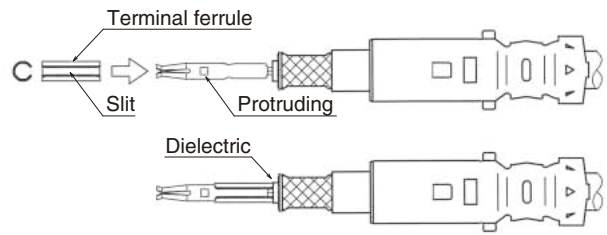

⑥ Set the aforementioned terminal block onto the insulator and enclose it from the top with one more insulator.

- Note 1. Set the protruding portion of the crimp terminal in the groove hole of the insulator.
- Note 2. Pull the cable with a force on the order of 4.9 N and check that the terminal block does not come out.

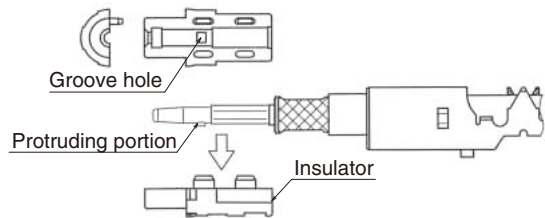

⑦ Use the special tool to cover the insulator with the outside tube, which was previously inserted.

- Note 1. Orient the outside tube as illustrated in the diagram, align the punched-in portion of the outside tube with the groove portion of the insulator (so that at both left and right, the split of the outer ferrule is aligned with the barrel bottom portion of the outside tube), and then insert.
- Note 2. Insert until the insulator stops at the lance of the outside tube.

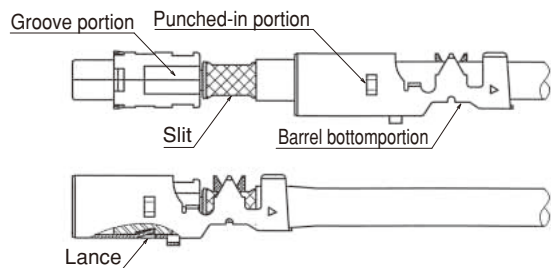

⑧ Use the special jig to crimp the crimp terminal.

Note 1. See "Crimping Conditions Table" for information about the crimping height.

Note 2. See "Crimping Quality Standards Manual" for information about crimping standards.

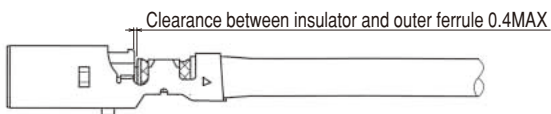

⑨ Insert the aforementioned outside tube block into the housing.

Note 1. Align the protruding portion of the outside tube with the groove portion of the housing, and then insert.

Note 2. Insert until the outside tube stops at the lance of the housing.

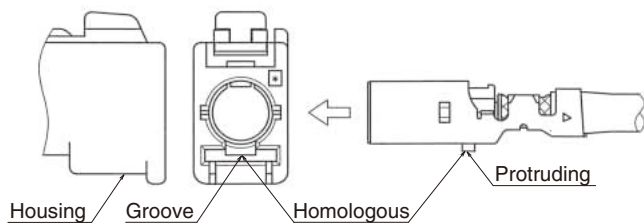

⑩ Insert the retainer into the housing.

Note 1. Insert until the retainer stops at the housing.

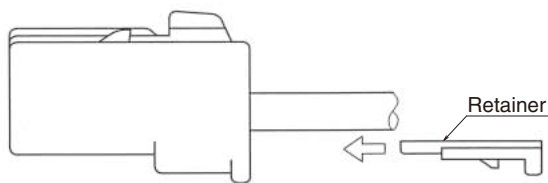

⑪ Inspect and complete the wiring.

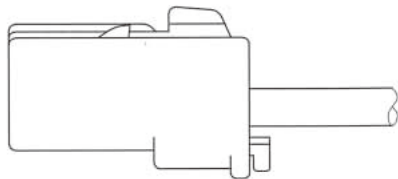

Note : The length (L) dimension after wiring and the cut cable length are described below.

Cut cable length: $L1 - 8.1$

$L2 + 11.0$

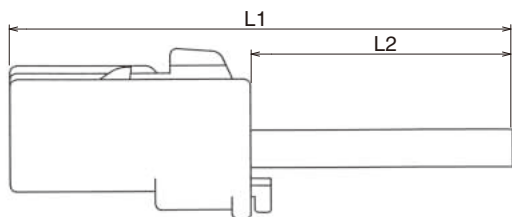

GT5

GT13

GT16

PO5G

GT19

GT21

GT26

GT36

GT11

GT17

GT32

GT3

GT7

GT10

GT18W

GT25

GT8E

GT9

GT15

■ Conversion Adapter

● SMA Conversion Adapter (Coupling portion: GT16G side jack - SMA side jack)



Note : The adapter does not have a lock portion and thus can only be used for performance measurements.

Part No.	HRS No.	Packaging	RoHS
GT16GS-HRMJ	766-0031-3	1	YES

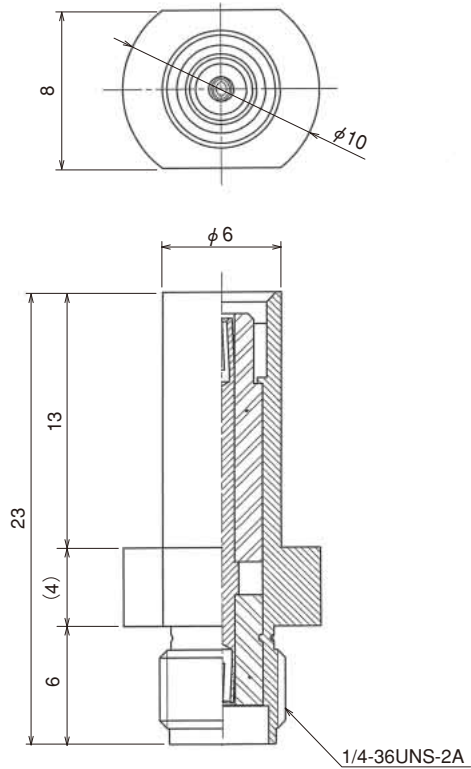

● SMA Conversion Adapter (Coupling portion: GT16G side plug - SMA side jack)



Note : The adapter does not have a lock portion and thus can only be used for performance measurements.

Part No.	HRS No.	Packaging	RoHS
GT16GP-HRMJ	766-0030-0	1	YES

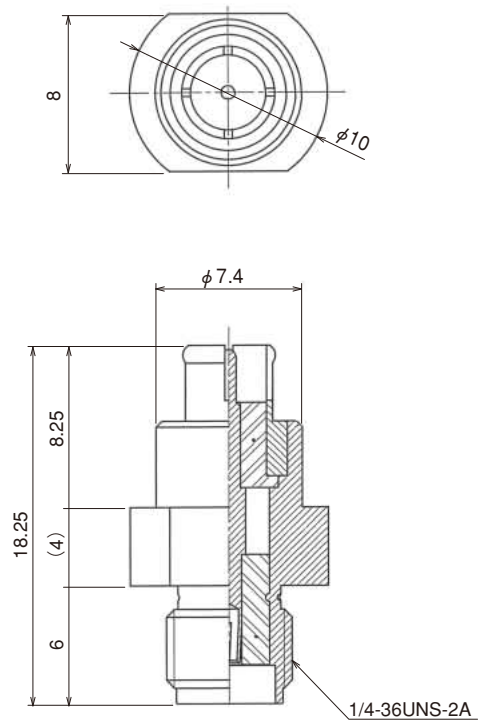

◆ F Connector Composition Table

Terminal Ferrule	Outer Ferrule	Inner Terminal	Insulator	Outer Terminal	Housing	Retainer
GT16G-FR	GT16G-1.5DHQS	GT16G-2428SCF	GT16G-SC	GT16GM-/1.6-2.9SC	GT16GM-1S-HU	GT16C-1P/S-R
				GT16G-/1.6-2.9SC	GT16G-1S-HU	
					GT16G-1S-HU (24)	
					GT16GD-1S-HU	
GT16GW-1S-HU	GT5W-1P/S-R					

◆ M Connector Composition Table

Terminal Ferrule	Outer Ferrule	Inner Terminal	Insulator	Outer Terminal	Housing	Retainer
GT16G-FR	GT16G-1.5DHQS	GT16G-2428PCF	GT16G-PC	GT16G-/1.6-2.9PC	GT16GM-1P-HU	-
					GT16GMN-1PP-HU	
					GT16GW-1P-HU	

Printed Circuit Board Type
GT16GM-1P-H
GT16GMP-1P-H
GT16G-1P-H
GT16GL-1P-H (70)
GT16GL-1P-H (71)
GT16GR-1P-H
GT16GD-1P-H

◆ Wiring Tools

Applicable Connectors		GT16GM-1S-HU GT16G-1S-HU GT16G-1S-HU (24) GT16GD-1S-HU	GT16GM-1P-HU GT16GMN-1PP-HU
Process 1	Cable strip processing	Schleuniger MP257, etc. (Commercial product)	Schleuniger MP257, etc. (Commercial product)
Process 2	Center terminal crimping	Crimping machine body type 105 + AP105-GT16G-2428P	Crimping machine body type 105 + AP105-GT16G-2428P
Process 3	Cable forming	Shield forming tool GT16G-1.5DHQS/CF-MD	Shield forming tool GT16G-1.5DHQS/CF-MD
Process 4	Outside ferrule insertion	Outside ferrule insertion tool GT16G-1.5DHQS/PR-MD	Outside ferrule insertion tool GT16G-1.5DHQS/PR-MD
Process 5	Terminal ferrule insertion	Terminal ferrule insertion tool GT16G-FR/PR-MD	Terminal ferrule insertion tool GT16G-FR/PR-MD
Process 6	Insulated washer assembly	Manual task	Manual task
Process 7	Outside tube insertion	Insulated washer press tool GT16G-SC/PR-MD	-
Process 8	Outside tube tightening	Hand press MOS-7 + GT16G-1.6-2.9S/CK-MP	Hand press MOS-7 + GT16G-1.6-2.9P/CK-MP
Process 9	Housing, (retainer) installation	Manual task	Manual task
Process 10	Inspection	High frequency characteristics test (Complete) Continuity / Withstand voltage test Inspection of external appearance	High frequency characteristics test (Complete) Continuity / Withstand voltage test Inspection of external appearance

◆ Mating Table

F Connectors	M Connectors
GT16GM-1S-HU	GT16GM-1P-H
	GT16GMP-1P-H
	GT16GM-1P-HU
GT16G-1S-HU	GT16GMN-1PP-HU
	GT16G-1P-H
	GT16GL-1P-H (70)
GT16G-1S-HU (24)	GT16GB-1PP-HU
	GT16GL-1P-H (71)
GT16GD-1S-HU	GT16GR-1P-H
	GT16GD-1P-H

◆ Test Data (Using 1.5D-2W Type cable)

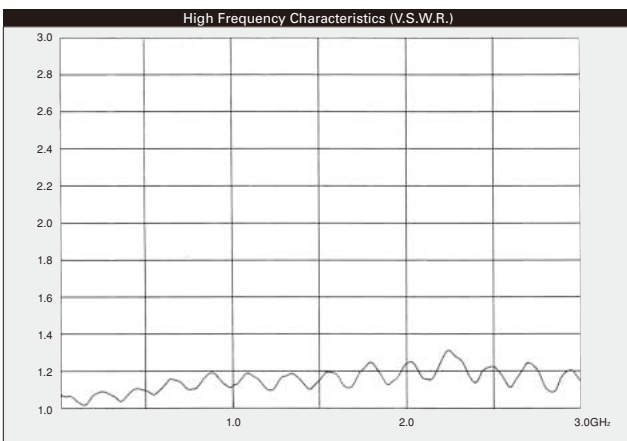

Note: Typical data using fully assembled and connected GT16-1P-H and the GT16-1S-HU.

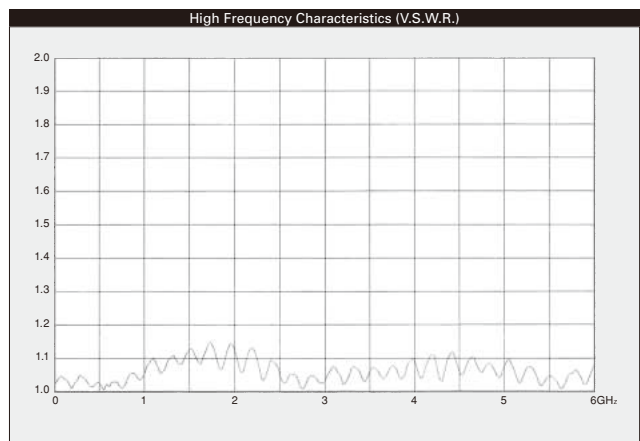

Note: The measurement data shown above were obtained using the GT16G-1P-H and GT16G-1S-HU.